

MANUAL NO. 207274  
REV B: 8/23/2021  
ECN 21-080

# SIoux

## BOTTOMLESS TANK

5/8" HARDWARE

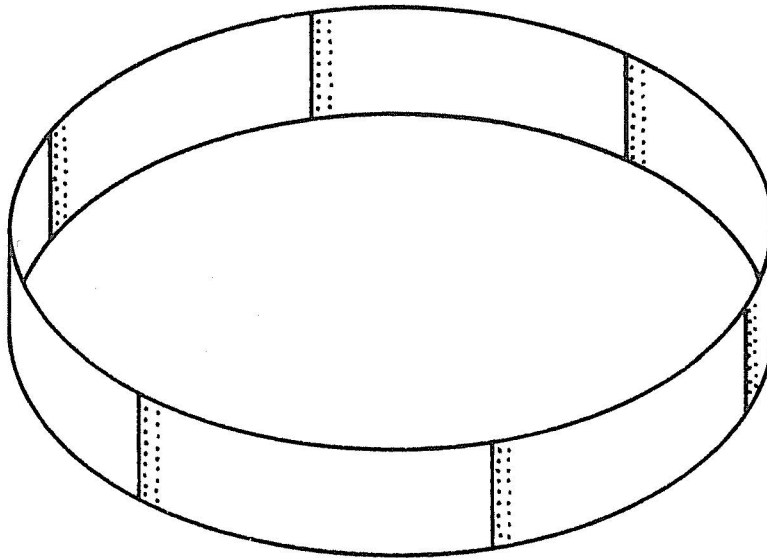

## PARTS & ASSEMBLY MANUAL

**IMPORTANT TO THE DEALER OR ERECTOR**  
**BE SURE THIS MANUAL IS RETURNED TO THE**  
**OWNER FOR FUTURE REFERENCE**

SIoux STEEL COMPANY, SIoux FALLS, SOUTH DAKOTA 57101

## **SAFETY**



WATCH OUT FOR THIS SYMBOL.  
THIS SYMBOL POINTS OUT IMPORTANT SAFETY PRECAUTIONS.  
IT MEANS ATTENTION-BE ALERT  
YOUR SAFETY IS INVOLVED.

**PLEASE HEED!** FAILURE TO DO SO MAY RESULT IN DEATH OR SERIOUS PERSONAL INJURY.



**1. Electrocutation Hazard**

Never locate the tank near or against electrical service wires or lines. Never submerge electrical devices not intended for contact with water in the tank. Any approved electrical device must be properly grounded.



**2.** Not for use as a swimming, bathing, or general recreation product.



**3.** Not for use as a water supply product for human consumption.



**4.** The tank should be tested at regular intervals to insure it is safe for animal use. Consult your local veterinarian, ASCS office, or Ag extension agent.



**5.** You should take whatever precaution may be necessary to insure that small animals, including calves, do not become trapped inside the tank.

# GENERAL INFORMATION

## PLANNING:

Before beginning assembly of the tank sidewall, consideration must be given to the site and tank "foundation" with regard to whether compliance with the ASCS is applicable. The ASCS has developed standards for steel rim water storage tanks which must be adhered to if cost sharing is under consideration. Contact your local ASCS office and ask for any technical information they may have available to assist you in the construction of your tank base.

## BASE DESIGN:

Generally, three (3) base designs are used in conjunction with "bottomless" stock tanks. They are:

1. Concrete
2. Engineered soil/sand/rock
3. PVC plastic membrane

Whichever design is selected, it is important that the sub grade have sufficient bearing capacity to support the weight of the wall and water which is stored. Additionally, the area surrounding the tank must provide adequate drainage to prevent soil erosion from occurring.

## CONCRETE BASE:

Concrete\* bases should not be installed where experience has shown the sulfate concentration in the soil to cause rapid concrete deterioration.

The base floor must be a minimum of 4" thick and reinforced with #3 bars on 12" centers or 6 x 6 x 6 gauge welded wire mesh. The floor must be placed on rock, fine gravel, or sand base. A minimum 4" layer of sand or fine gravel is recommended to be placed between the floor and sub-base material. The floor should extend at least 2 feet beyond the periphery of the tank side wall. Where the steel is embedded into the floor, the slab thickness or depth should increase proportionately and a asphalt or similar coating used to protect the steel.

Water supply lines, overfills, drains, and emptying drains are at the discretion of the owner, but must comply with local codes and/or ASCS standards where applicable.

\*Minimum compressive strength shall be 3,500 psi.

## BOTTOMLESS TANK PART LIST

### SV1525BT (15' X 25")

Part #	Description	Qty
SV2512F2015LBST	CURVED PANEL- 15FT-25IN/12GA-2Z FULL- 5/8IN-GALV-LOGO/BTMLS STK TANK	1
S163666	SEALANT- .125 X .75 BEAD/FT	30ft
S199995	SCREW-.625 HHC- 11 X 1.00 GR5 W/LAM STEEL/NEOPRENE WASHER	56
S154055	NUT-.625 HEX -11 GRA ZP	56

### SV1533BT (15' X 33")

Part #	Description	Qty
SV3312F2015	CURVED PANEL-15FT-33IN/12GA-2Z FULL- 5/8IN-GALVANIZED	4
SV3312F2015LBST	CURVED PANEL- 15FT-33IN/12GA-2Z FULL- 5/8IN-GALV-LOGO/BTMLS STK TANK	1
S163666	SEALANT- .125 X .75 BEAD/FT	30ft
S199995	SCREW-.625 HHC- 11 X 1.00 GR5 W/LAM STEEL/NEOPRENE WASHER	65
S154055	NUT-.625 HEX -11 GRA ZP	65

### SV2125BT (21' X 25")

Part #	Description	Qty
SV2512F2021	CURVED PANEL-21FT-25IN/12GA-2Z FULL- 5/8IN-GALVANIZED	6
SV2512F2021LBST	CURVED PANEL- 21FT-25IN/12GA-2Z FULL- 5/8IN-GALV-LOGO/BTMLS STK TANK	1
S163666	SEALANT- .125 X .75 BEAD/FT	30ft
S199995	SCREW-.625 HHC- 11 X 1.00 GR5 W/LAM STEEL/NEOPRENE WASHER	77
S154055	NUT-.625 HEX -11 GRA ZP	77

### SV2133BT (21' X 33")

Part #	Description	Qty
SV3312F2021	CURVED PANEL-21FT-33IN/12GA-2Z FULL- 5/8IN-GALVANIZED	6
SV23312F2021LBST	CURVED PANLE- 21FT-33IN/12GA-2Z FULL- 5/8IN-GALV-LOGO/BTMLS STK TANK	1
S163666	SEALANT- .125 X .75 BEAD/FT	30ft
S199995	SCREW-.625 HHC- 11 X 1.00 GR5 W/LAM STEEL/NEOPRENE WASHER	91
S154055	NUT-.625 HEX -11 GRA ZP	91

### SV2725BT (27' X 25")

Part #	Description	Qty
SV2512F2027	CURVED PANEL-27FT-25IN/12GA-2Z FULL- 5/8IN-GALVANIZED	8
SV2512F2027LBST	CURVED PANEL- 27FT-25IN/12GA-2Z FULL- 5/8IN-GALV-LOGO/BTMLS STK TANK	1
S163666	SEALANT- .125 X .75 BEAD/FT	30ft
S199995	SCREW-.625 HHC- 11 X 1.00 GR5 W/LAM STEEL/NEOPRENE WASHER	99
S154055	NUT-.625 HEX -11 GRA ZP	99

### SV2733BT (27' X 33")

Part #	Description	Qty
SV3312F2027	CURVED PANEL-27FT-27IN/12GA-2Z FULL- 5/8IN-GALVANIZED	8
SV3312F2027LBST	CURVED PANEL- 27FT-27IN/12GA-2Z FULL- 5/8IN-GALV-LOGO/BTMLS STK TANK	1
S163666	SEALANT- .125 X .75 BEAD/FT	60ft
S199995	SCREW-.625 HHC- 11 X 1.00 GR5 W/LAM STEEL/NEOPRENE WASHER	117
S154055	NUT-.625 HEX -11 GRA ZP	117

# PLAN VIEW

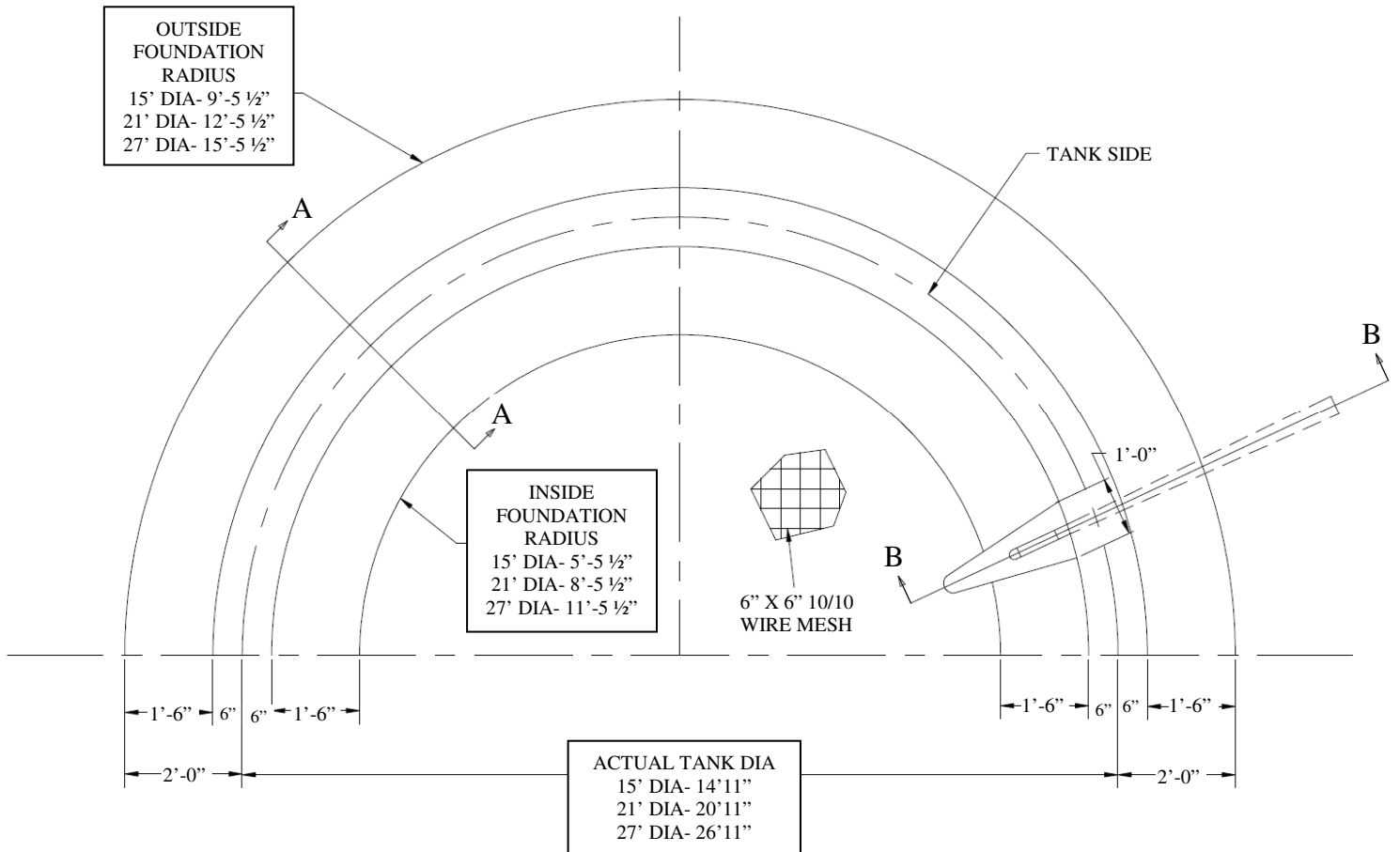

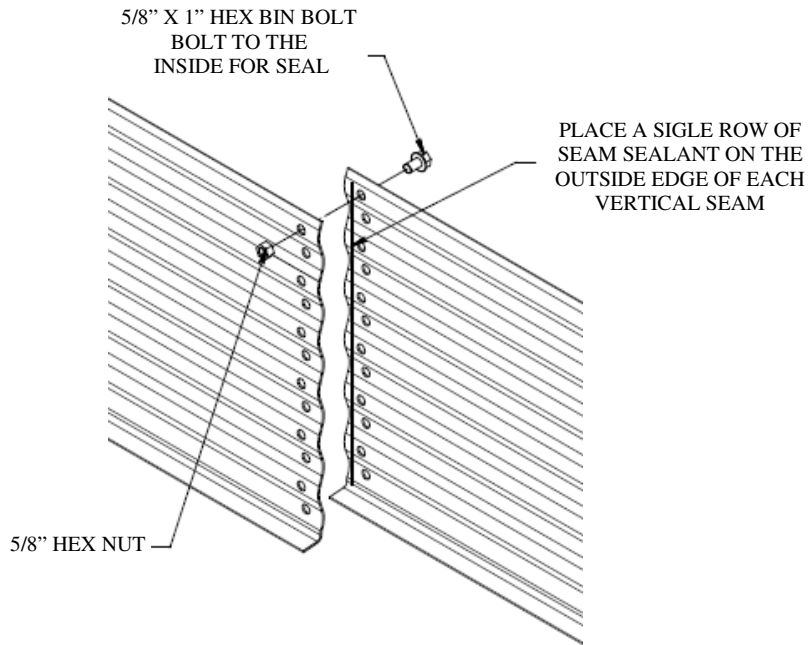

TYPICAL SIDEWALL SHEET SEAM SEALANT DETAIL

PLAN SCHEDULE				
PART NO.	DIA.	'A' HT	CONCRETE CU. YARDS	WIRE MESH 6" X 6" 10/10 SQ. FT
S1525BT	15'	25"	5 1/2	267
S1533BT	15'	33"		
S2125BT	21'	25"	9	468
S2133BT	21'	33"		
S2725BT	27'	25"	13	724
S2733BT	27'	33"		

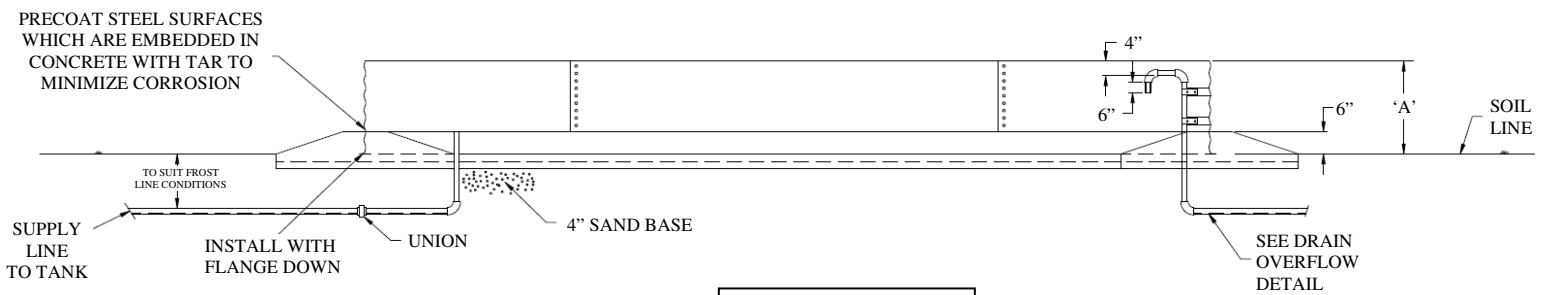

CROSS SECTION

## IMPORTANT!

### Please Note:

This plan is in accordance with USDA recommendations provided on guide plan No. 14.1, Rev 8/80. This plan is only a suggested foundation plan which may or may not be applicable to suit your specific requirements.

### NOTES:

1. With slip joint design, stand pipe assy may be removed to drain tank.
2. Glue one end of slip joint to overflow tube. Grease exposed end to provide a seal when engaged with embedded drain pipe.
3. All pipes and fittings to be 1 1/2' ABS plastic pipe.
4. Design supply line to meet water source requirements.

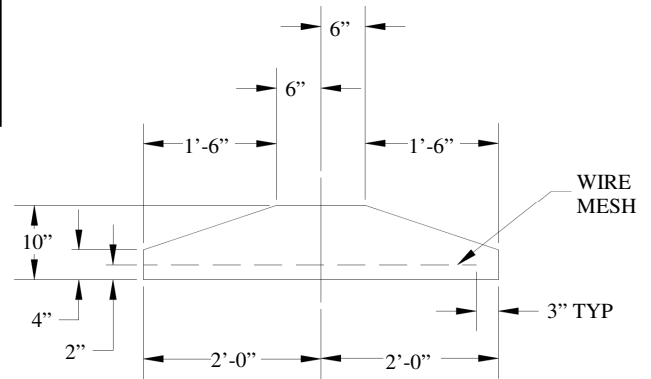

FOUNDATION DETAIL  
SECTION A-A

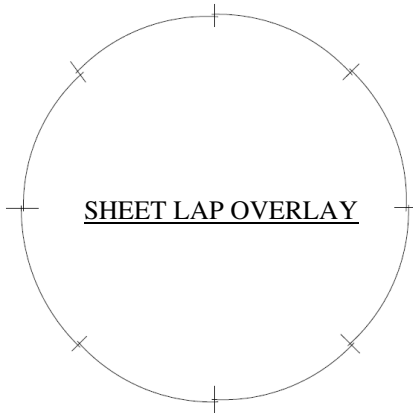

SHEET LAP OVERLAY

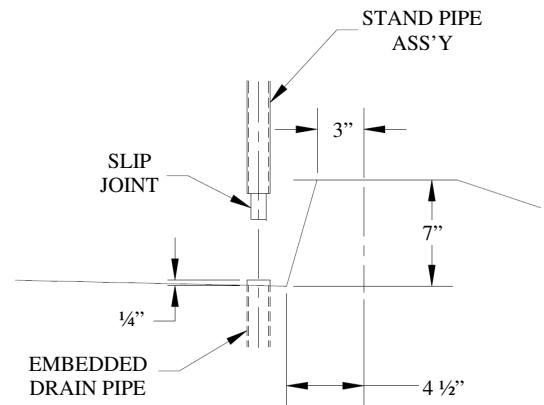

ENLARGED VIEW  
DRAIN OVERFLOW DETAIL

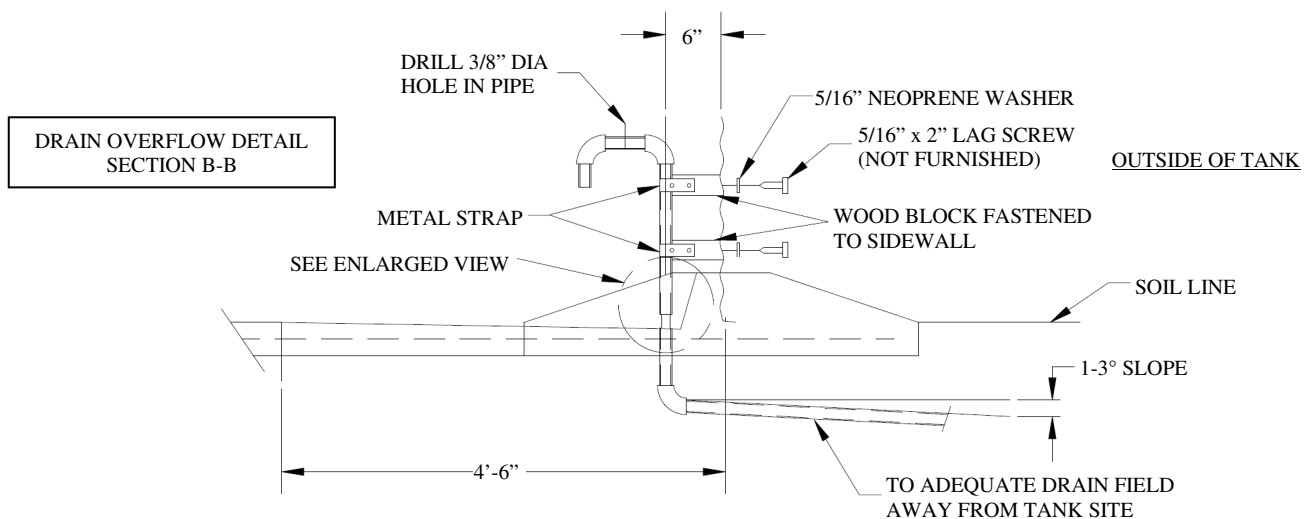

DRAIN OVERFLOW DETAIL  
SECTION B-B

OUTSIDE OF TANK

TO ADEQUATE DRAIN FIELD  
AWAY FROM TANK SITE

Sioux Steel Co.  
 196 1/2 East 6th Street  
 P.O. Box 1265  
 Sioux Falls, SD 57101-1265



Phone: .....(800) 557-4689  
 (605) 336-1750  
 (605) 557-4689  
 Sales Fax: ....(605) 357-8597  
 Fax: .....(605) 336-2528

**NEW PRODUCT WARRANTY**  
**HIQUAL & LIVESTOCK EQUIPMENT**

**A. GENERAL PROVISIONS.** "Sioux Steel" means Sioux Steel Company, 196 1/2 East Sixth Street, Sioux Falls, South Dakota 57104. The warranties described below are provided by Sioux Steel to the original purchasers of new products purchased from Sioux Steel or from an authorized Sioux Steel Dealer (the "Products"). Under these warranties, Sioux Steel will, at its option, repair or replace at its factory any Product covered under these warranties which is found to be defective in material and workmanship during the applicable warranty term or refund the purchase price paid for the defective Product. Customer will be responsible for labor charges for removing the defective Product and reinstalling the repaired or replacement Product, any premium charge for overtime labor requested of Sioux Steel and shipping charges to and from Sioux Steel's factory. These warranties are not transferrable.

**B. WARRANTY PERIOD.** Subject to exclusions and limitations set forth herein, each new Product is warranted for the number of years specified below. Each warranty term begins from the date of purchase to the (End User) regardless of delay in receipt of the Product by Customer due to the time required to process, handle, ship, assemble, construct and install the Product. Customer must retain proof of the date of purchase. Replacement parts for and repairs to the Product will be warranted only for the remainder of the original warranty term. The replacement parts for or repairs to the Product will not extend the warranty term beyond the original warranty term. Products described below include all parts, components and accessories.

Product/Part Name	8 Years	3 Years	Lifetime Warranty	1 Year
Victory, Cattleman's, Heavy Duty and Super Six steel construction livestock gates labeled through the Company's "Lifetime Guarantee Gate Program" ("Lifetime Guaranteed Gates")			X	
Locking Mechanisms			X	
Rump Fingers			X	
Cleated Rubber Flooring			X	
Squeeze Chutes	X			
Head Gates	X			
Calving Pens		X		
Hydraulic Chute	X			
Hydraulic Components				X
Hydraulic Calf Chute	X			
Hydraulic Components				X
Palp Cage (Pin On)		X		
Crowding Tubs		X		
Scale Equipment		X		
Adjustable Alleys		X		
Slick Door (Pin On)		X		
Bow Gates		X		
Panel - Heavy Duty and 2" Range Tough		X		
Portable Systems and chute				X

Product/Part Name	8 Years	3 Years	Lifetime Warranty	1 Year
All Other Livestock Equipment, including Bulk Bins, Poly products and all Livestock Gates that are not labeled through the "Guarantee Gate Program" as provided above				X
Post Pounder <b>Note:</b> Commercial or Government use (6 Month warranty)				X

Exclusions specific to Livestock Equipment: Damage or loss of any kind from (1) storage of feed products that are not free-flowing or that have a density greater than 40 pounds per square foot; and (2) the storage of materials other than free-flowing livestock feed.

**C. ITEMS COVERED SEPARATELY.** The Sioux Steel warranties do not cover any parts, components or materials that are part of the Product, or used in conjunction with the Product, that are not manufactured by Sioux Steel. Such parts, components and materials will be subject to the warranties provided by the manufacturer, if any.

**D. WHAT IS NOT WARRANTED.** Sioux Steel does not warrant and is not responsible for the following: (1) used products; (2) modification or alteration of the Products; (3) Products that have not been properly installed or not installed in accordance with the instruction manual, improper assembly, or improper construction by any persons other than Sioux Steel employees; (4) depreciation, damage or loss caused by the use of parts, components or accessories not provided by Sioux Steel, unauthorized repairs, normal wear, lack of necessary and proper maintenance, a failure to follow operating instructions/recommendations, misuse, lack of proper protection during storage, vandalism or theft, exposure to the elements or corrosive materials, accidents or acts of nature including lightning, flooding, hail, straight winds and tornadoes; and (5) cosmetic damage or damage that does not hinder the functionality of the Products. (6) Warranty does not cover corrosion.

**E. LIFETIME GUARANTEED GATES.** The Limited Warranty for New Sioux Steel Company Products shall apply to the Lifetime Guaranteed Gates ("Gates") for the life of the original purchaser with the exception of Section D above. Sioux Steel does not warrant and is not responsible for the following: (1) modification or alteration of the Gates; (2) cosmetic damage, normal wear and tear or damage that does not hinder the functionality of the Gates, including fading of the color; (3) damage caused by use for purposes inconsistent with its intended purpose or design; (4) damage due to use of any parts or components not supplied by the Sioux Steel.

**F. LIMITATIONS OF WARRANTIES AND CUSTOMER'S REMEDIES.** To the extent permitted by law, neither Sioux Steel, the Dealer nor any person or company affiliated with either of them makes any warranties, representations, conditions or promises express or implied as to the quality, performance or freedom from defects of the Products covered by these warranties other than those set forth herein. THERE ARE NO IMPLIED WARRANTIES OF MERCHANTABILITY OR FITNESS FOR A PARTICULAR PURPOSE. NEITHER SIOUX STEEL, THE DEALER, NOR ANY PERSON OR COMPANY AFFILIATED WITH EITHER OF THEM WILL BE LIABLE FOR ANY DAMAGES, INCLUDING, BUT NOT LIMITED TO, INCIDENTAL, SPECIAL, EXEMPLARY, CONSEQUENTIAL, LOST PROFITS AND REVENUES, LOST USE OF THE PRODUCTS OR ANY OTHER PROPERTY, BODILY INJURY OR PROPERTY DAMAGE CLAIMS OF ANY PERSON, LOST COMMODITIES, REMOVAL OR STORAGE COSTS FOR THE PRODUCTS, OTHER EQUIPMENT AND COMMODITIES, DAMAGE TO THE ENVIRONMENT ARISING FROM OR IN ANY MANNER RELATED TO ANY RELEASE OF HAZARDOUS MATERIALS, AND REMEDIATION EXPENSES THEREFORE, WHETHER BASED ON CONTRACT, TORT, STRICT LIABILITY OR ANY OTHER LEGAL BASIS, EVEN IF ADVISED OF THE POSSIBILITY OF SUCH DAMAGES. IN NO INSTANCE WILL SIOUX STEEL, THE DEALER OR ANY PERSON OR COMPANY AFFILIATED WITH EITHER OF THEM BE LIABLE TO CUSTOMER OR ANY PERSON IN AN AMOUNT IN EXCESS OF THE PURCHASE PRICE PAID BY CUSTOMER FOR THE PRODUCT.

**G. NO DEALER WARRANTY.** THE DEALER HAS NO AUTHORITY TO MAKE ANY WARRANTY, REPRESENTATION, CONDITION OR PROMISE ON BEHALF OF SIOUX STEEL, OR TO MODIFY THE TERMS OR LIMITATIONS OF THIS WARRANTY IN ANY WAY.

**H. GOVERNING LAW/VENUE.** These warranties, and all terms set forth herein, are governed by the laws of the State of South Dakota and, where applicable, the laws of the United States of America. Any and all disputes arising from these warranties, the purchase and use of the Products, bodily injury and property damage claims or otherwise must be venued in the South Dakota Circuit Court sitting in Minnehaha County, South Dakota. Customer agrees to such venue and waives any challenge to such court's jurisdiction based upon lack of personal jurisdiction or inconvenience.

**I. SECURING WARRANTY SERVICE.** In order to receive warranty services, customer must give Sioux Steel written notice of a warranty claim within 30 days of the date of discovery of the defective materials or workmanship, and Customer must complete the following steps:

- (1) Obtain from Sioux Steel a Return Goods Authorization Number ("RGA Number") by calling the Customer Service Department at 1-800-557-4689, and providing the following information:
  - The name of the territory representative, Dealer or Sioux Steel salesperson from whom the Product was purchased.
  - The Dealer's identification number.
  - The invoice number and date of purchase.
  - Customer's name, phone number, fax number, mailing address and email address.
  - The date that the Product will be returned.
- (2) Pay the shipping charges to ship the Product to Sioux Steel's factory, and the return shipping charges.
  - Sioux Steel  
Boyd Distribution  
221 E 11<sup>th</sup> Ave  
Lennox, SD 57039
- (3) Reason for Return.
- (4) Make sure the RMA Number is labeled visibly on the returned product.