

TOP VIEW

NOZZLE SCHEDULE						
ITEM	SIZE	RATING	TYPE	MATL.	REMARKS	NOTES
A	2"	N.P.T.	W.F.	C.S.	PRIMARY	SUCTION W/DROP TUBE
B	4"	N.P.T.	H. CPL.	C.S.	PRIMARY	EMERGENCY VENT
C	4"	N.P.T.	H. CPL.	C.S.	SECONDARY	EMERGENCY VENT
D	2"	N.P.T.	W.F.	C.S.	PRIMARY	UPDRAFT VENT
E	2"	N.P.T.	W.F.	C.S.	SECONDARY	THREAD PROTECTOR
F	1"	N.P.T.	W.F.	C.S.	SECONDARY	DIPSTICK
G	2"	N.P.T.	W.F.	C.S.	PRIMARY	AT-A-GLANCE GAUGE
H	2"	N.P.T.	W.F.	C.S.	PRIMARY	FILL BOX

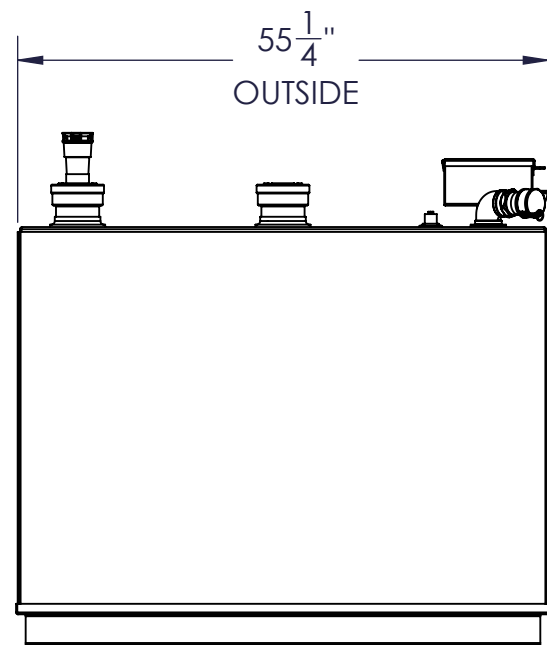

LEFT SIDE

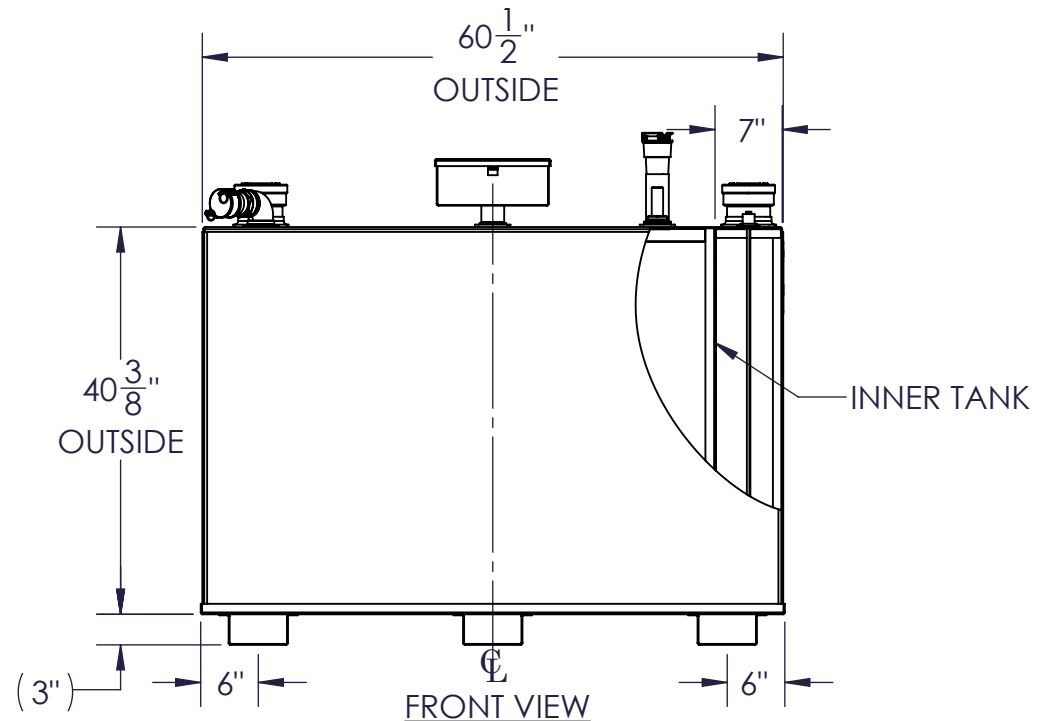

FRONT VIEW

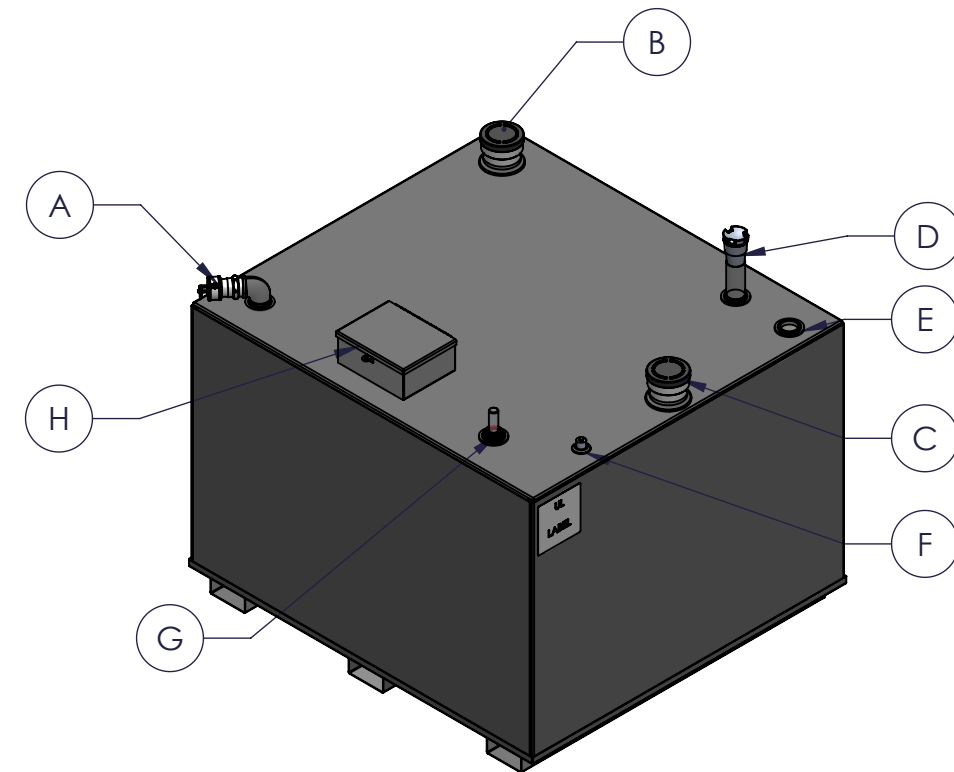

NOTES:

- A. QUANTITY:
- B. MATERIAL: H.R. CARBON STEEL
- C. INNER TANK/OUTER TANKS: 12 GA. W/10 GA. COMMON TOP.
- D. DESIGN & OPERATING PRESSURE: ATMOSPHERIC.
- E. DESIGN & OPERATING TEMPERATURE: AMBIENT.
- F. TANK TO BE BUILT & LABELED PER U.L. SPEC. #142.
- G. TANK TO BEAR MANUFACTURERS & U.L. LABELS ONLY.
- H. TANK TO BE AIR TESTED WITH WATER & SOAP SUDS SOLUTION.
- I. INTERIOR: REMOVE WELD SLAG (SHIP CLEAN & DRY).
- J. EXTERIOR: GRAY PRIMER INCLUDED; SEE SALES ORDER FOR TOP COAT.
- K. ALL FITINGS TO BE PROTECTED FOR SHIPMENT.
- L. CUSTOMER HAS THE RESPONSIBILITY TO VERIFY ALL DIMENSIONS.

APPROVAL FOR CONSTRUCTION
SCHEDULE A - MASTER TERMS &
CONDITION OF SALE*

APPROVED AS DRAWN.

APPROVED WITH NOTED CHANGES,
CONSTRUCTION WILL BE SCHEDULED
WHEN SIGNED DRAWING AND
CONFIRMED ORDER ARE RECEIVED.

SIGNATURE: _____

DATE: _____

*All pages of this Schedule A are incorporated by
reference and are a part of the additional terms of
the Master Terms & Conditions of Sale.
www.newberrytanks.com/masterterms.pdf

SALES ORDER: -

Newberry Tanks
New Thinking

Phone: 870-735-4473 Fax: 870-735-3982

WEIGHT (LBS): 974.0

All units inches
unless stated
otherwise

DESCRIPTION:
500 GALLON RECTANGULAR UL 142 DOUBLE WALL TANK

CUSTOMER: _____ P.O.# _____

DATE: 11/2/2020 SCALE: _____ DWG.# FTDW-500

DRAWN BY: AJC

SHEET 1 OF 1