

4

3

2

1

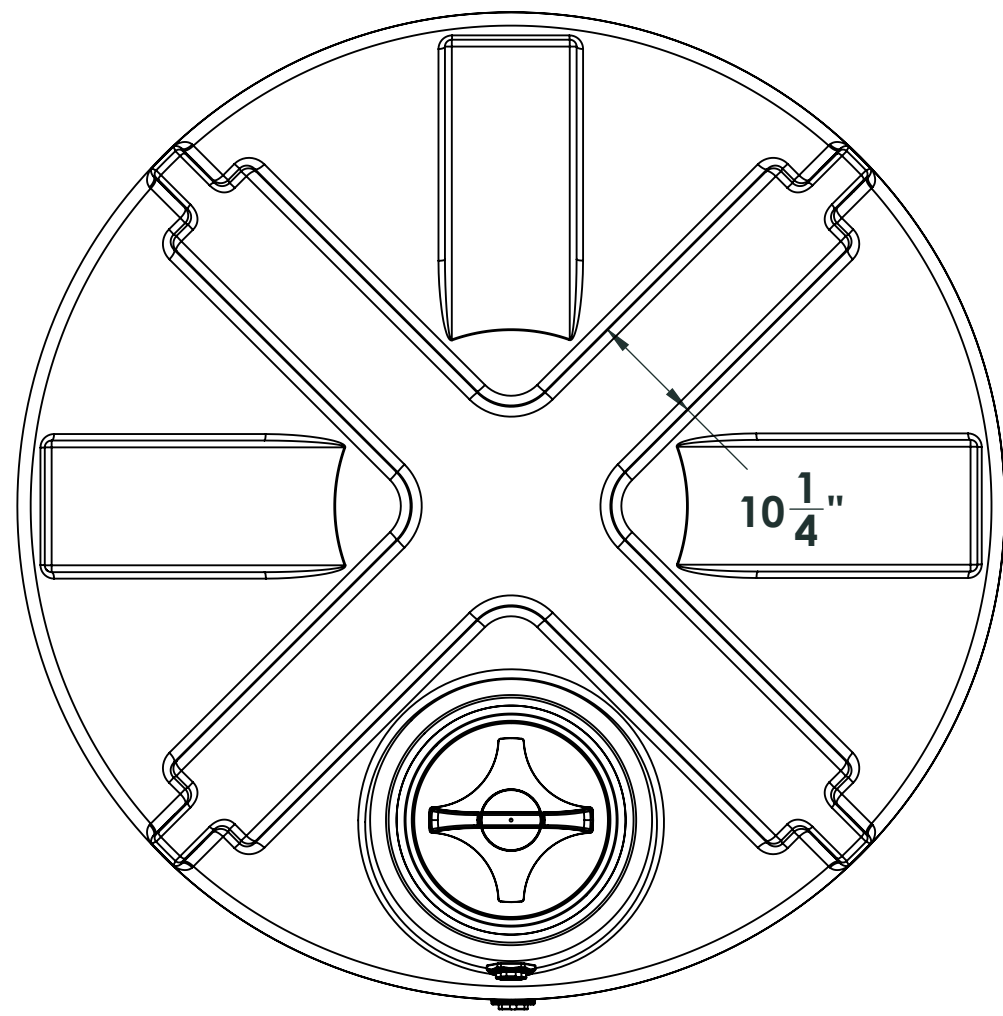

16 inch lid
2 inch threaded fitting

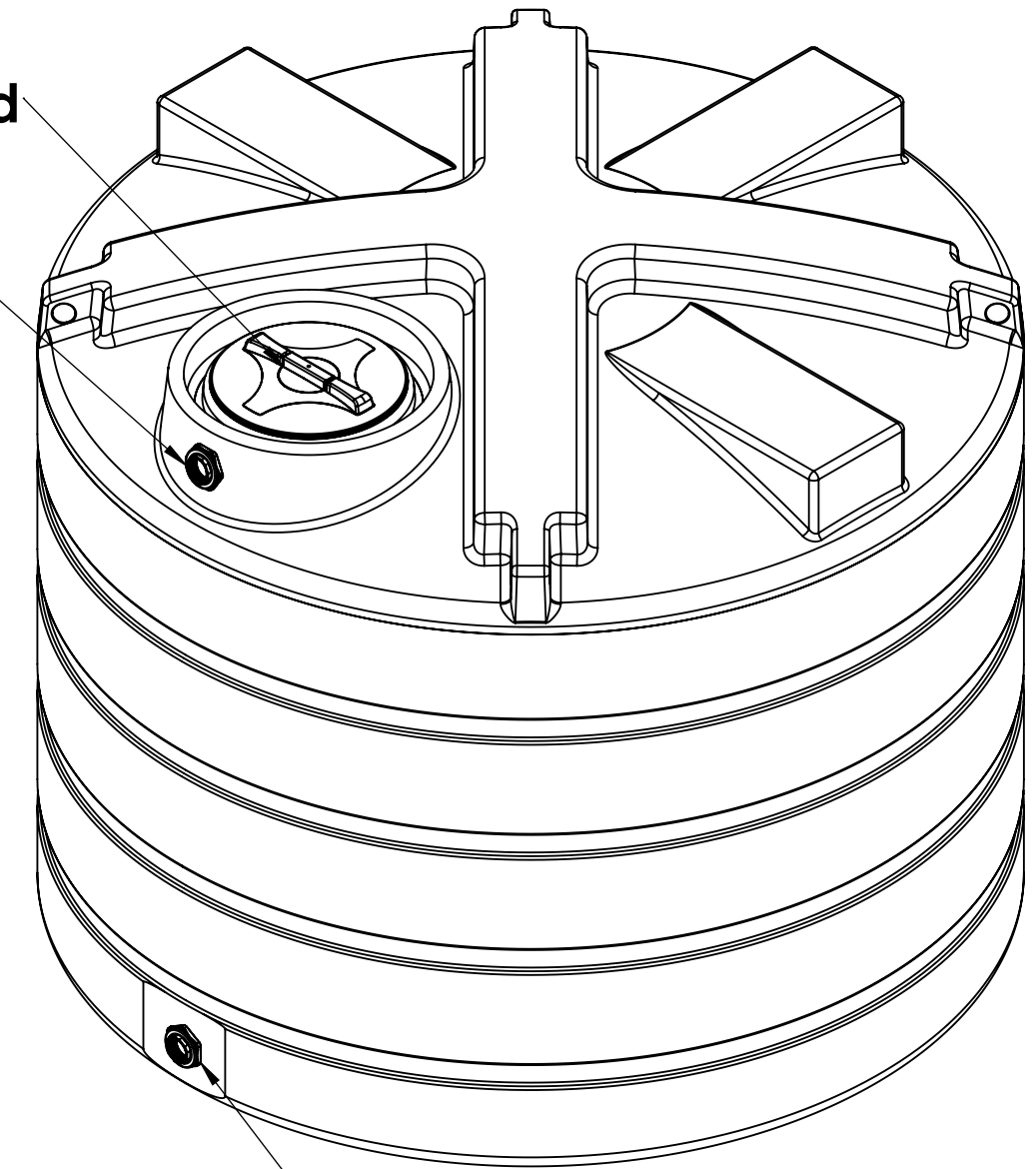

2 inch threaded fitting

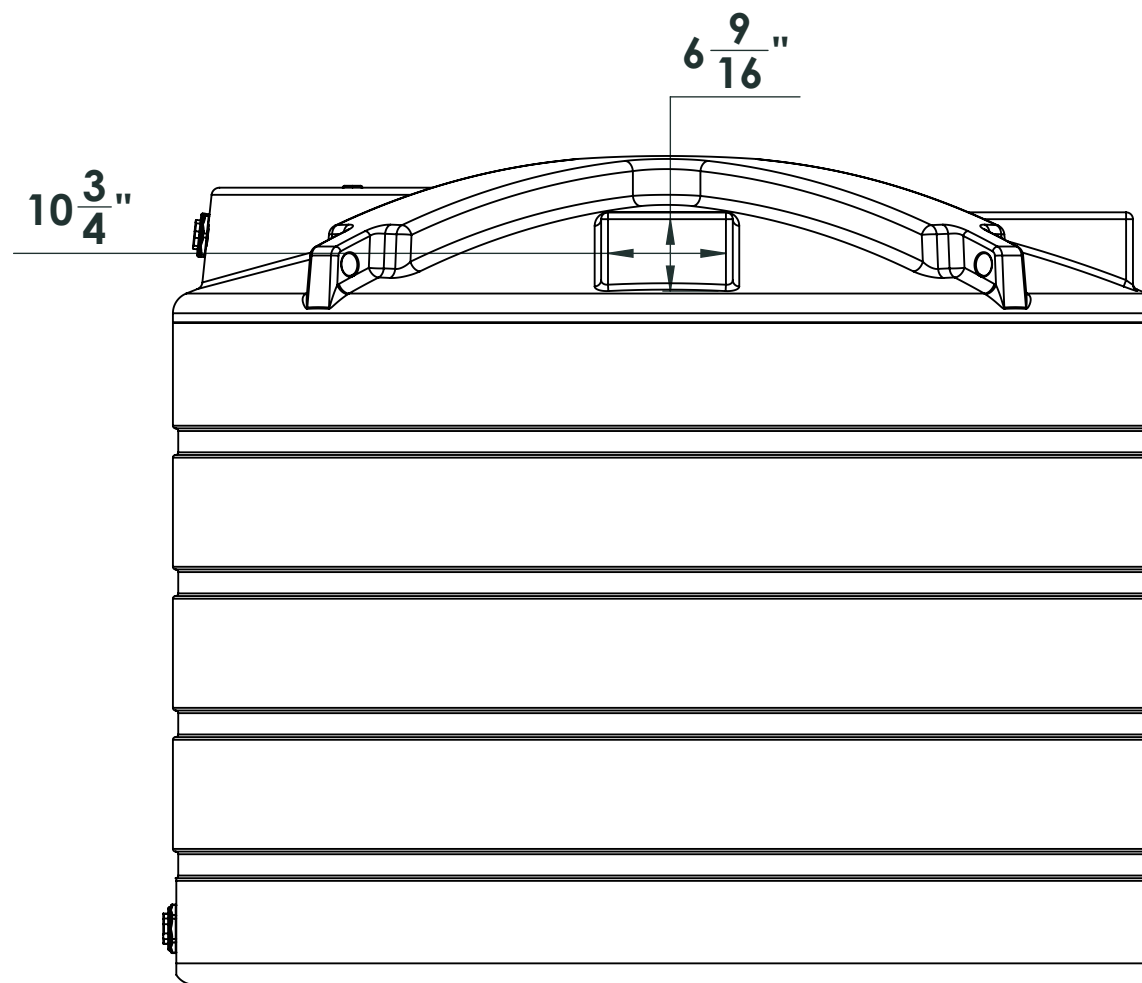
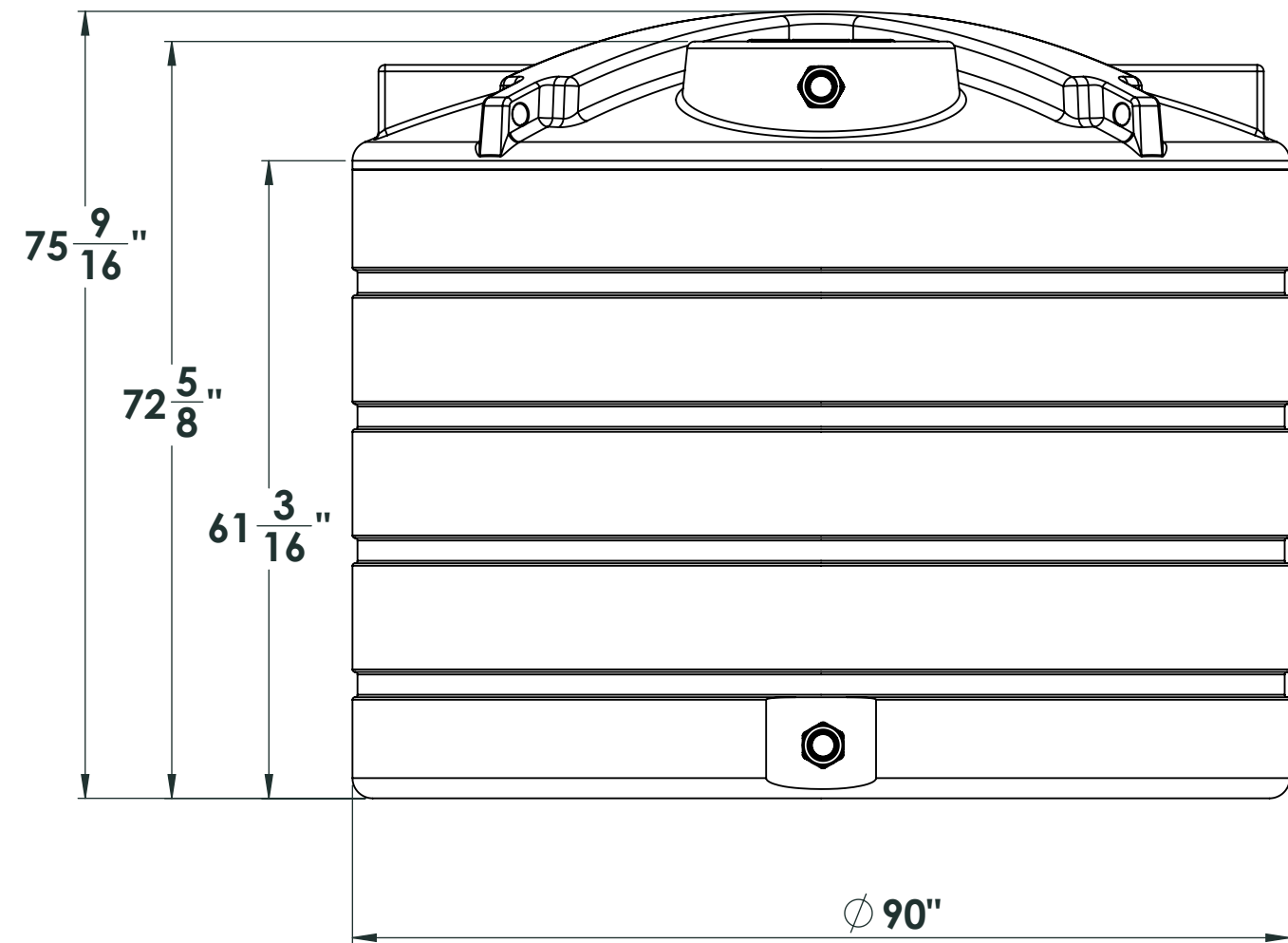

NOTE: Allow +/- 1.5% Shrinkage

PROPRIETARY AND CONFIDENTIAL
THE INFORMATION CONTAINED IN THIS DRAWING IS THE SOLE PROPERTY OF ENDURAPLAS LLC. ANY REPRODUCTION IN PART OR AS A WHOLE WITHOUT THE WRITTEN PERMISSION OF ENDURAPLAS LLC IS PROHIBITED.

UNLESS OTHERWISE SPECIFIED:		DRAWN	NAME	DATE	ENDURAPLAS LLC	
DIMENSIONS ARE IN INCHES		CHECKED	DNS	10/31/16		TITLE:
TOLERANCES:		ENG APPR.				TLV01650
FRACTIONAL ±		MFG APPR.				SIZE DWG. NO. REV
ANGULAR: MACH ± BEND ±		Q.A.			C 1	
TWO PLACE DECIMAL ±		COMMENTS:			SCALE: 1:50 WEIGHT: SHEET 1 OF 1	
THREE PLACE DECIMAL ±						
INTERPRET GEOMETRIC TOLERANCING PER:	MATERIAL	FINISH				
NEXT ASSY	USED ON	APPLICATION				
		DO NOT SCALE DRAWING				

4

3

2

1