

8 7 6 5 4 3 2 1

D  
C  
B  
A

D  
C  
B  
A

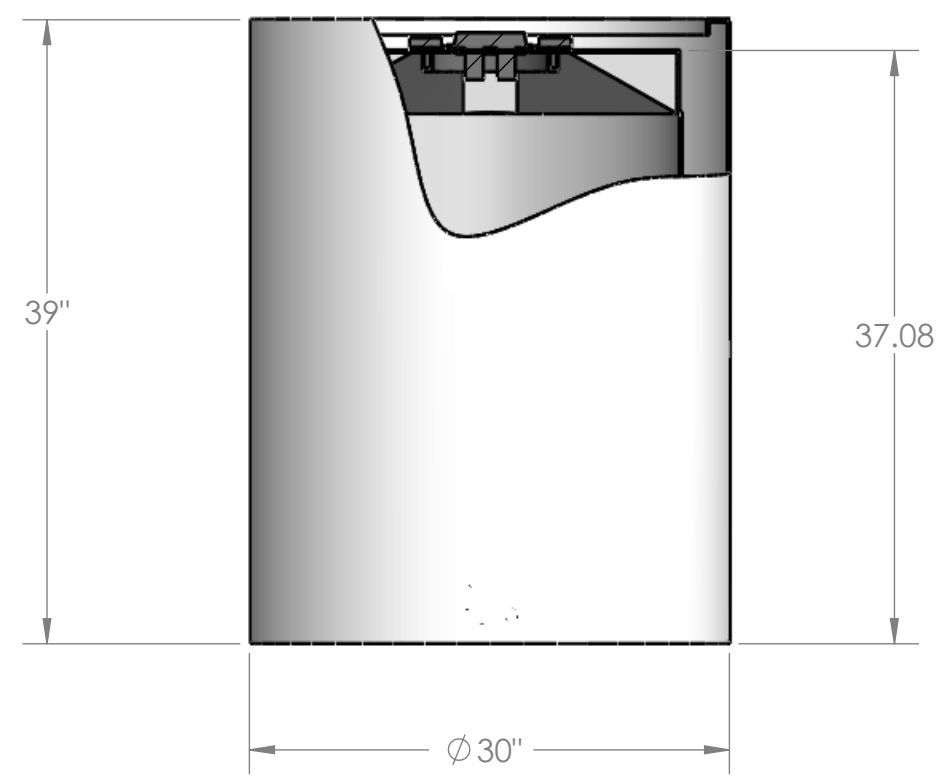
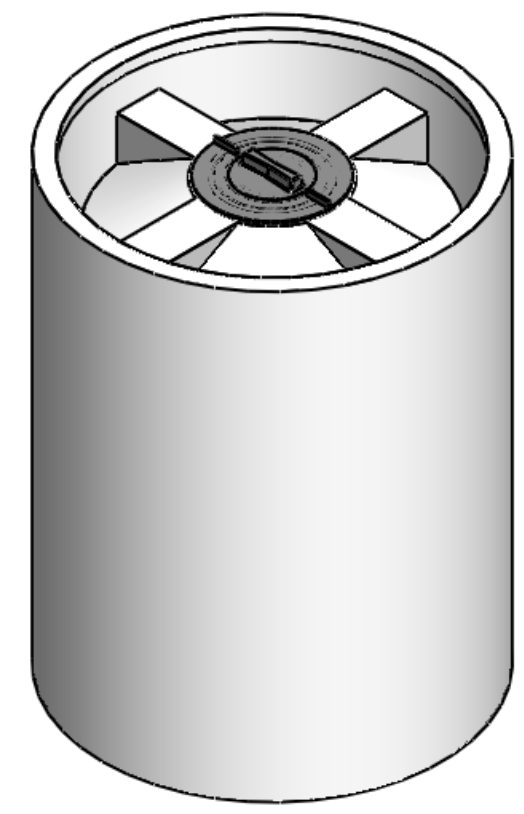
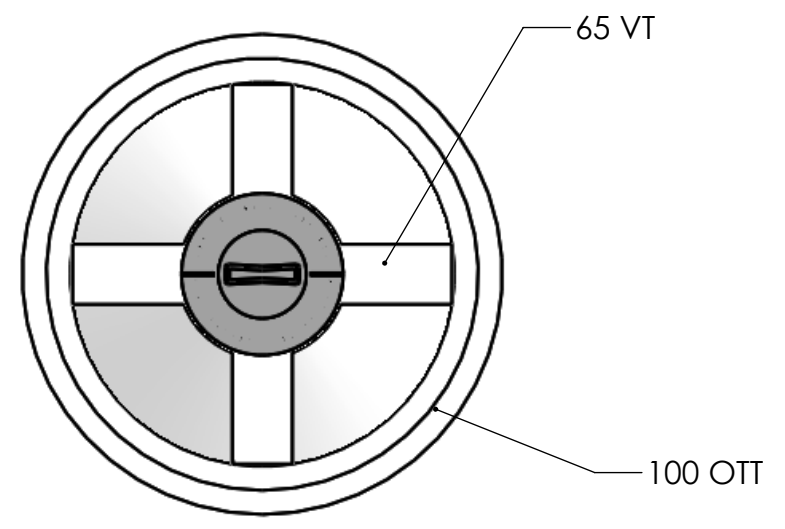

NOTES:

- 1. MATERIAL: HDPE
- 2. PRIMARY TANK: STD. = 2.0 S.G. 20 LBS
- 3. CONTAINMENT: STD. = 2.0 S.G. 30 LBS
- 4. SHIPPING WEIGHT: 50 LBS.

**PROPRIETARY AND CONFIDENTIAL**  
 THE INFORMATION CONTAINED IN THIS DRAWING IS THE SOLE PROPERTY OF <INSERT COMPANY NAME HERE>. ANY REPRODUCTION IN PART OR AS A WHOLE WITHOUT THE WRITTEN PERMISSION OF <INSERT COMPANY NAME HERE> IS PROHIBITED.

		UNLESS OTHERWISE SPECIFIED:		NAME	DATE	CUSTOM ROTO-MOLDING, INC.				
		DIMENSIONS ARE IN INCHES		DRAWN	EBW	10-22-10	TITLE: <b>65 VT - 100 OTT</b>			
		TOLERANCES:		CHECKED						
		FRACTIONAL ±		ENG APPR.						
		ANGULAR: MACH ± BEND ±		MFG APPR.						
		TWO PLACE DECIMAL ±		Q.A.			SIZE	DWG. NO.	REV	
		THREE PLACE DECIMAL ±		COMMENTS:			<b>B</b>	<b>65 VTWC</b>		
		INTERPRET GEOMETRIC TOLERANCING PER:						SCALE: 1:12	WEIGHT:	SHEET 1 OF 1
		MATERIAL								
		FINISH								
NEXT ASSY	USED ON	DO NOT SCALE DRAWING								
APPLICATION										

8 7 6 5 4 3 2 1