

8 7 6 5 4 3 2 1

D
C
B
A

D
C
B
A

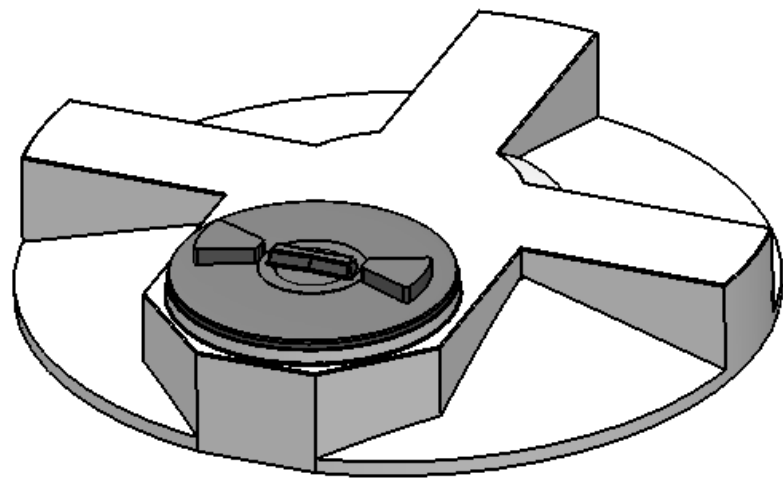
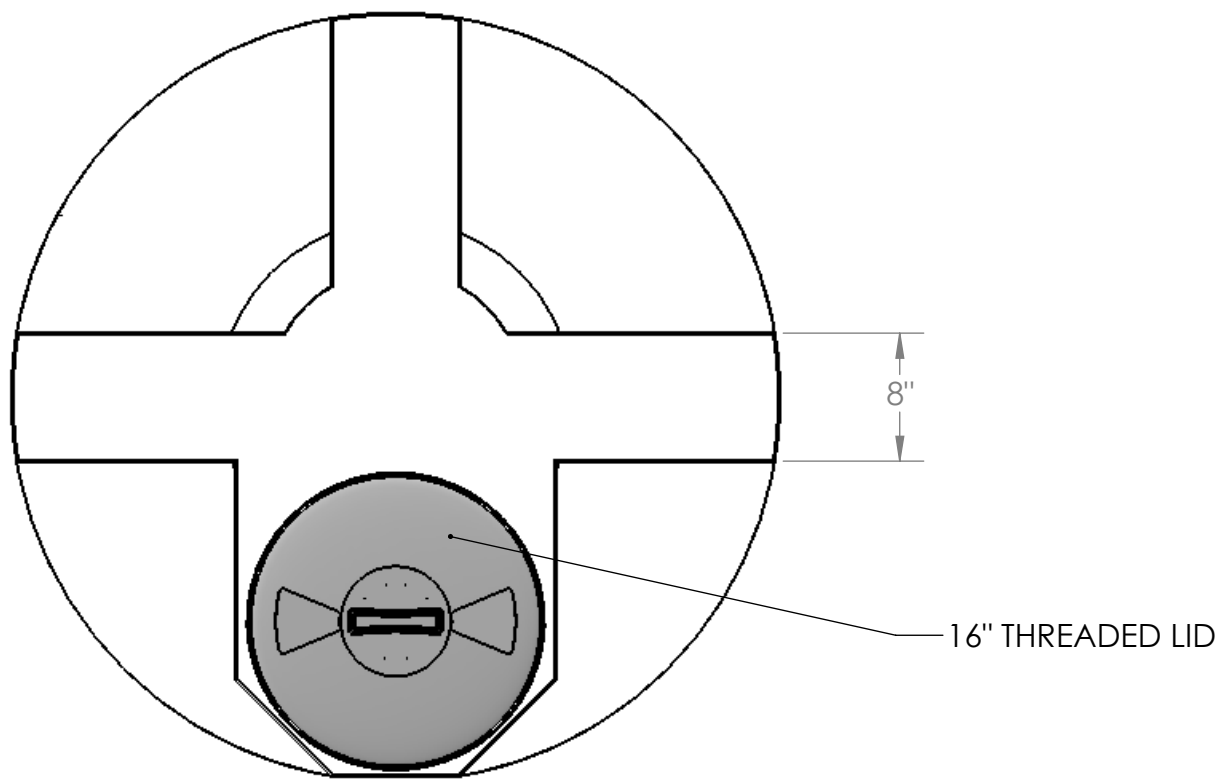

NOTES:

- 1. MATERIAL: HDPE
- 2. MOLDED WT. 30 LBS

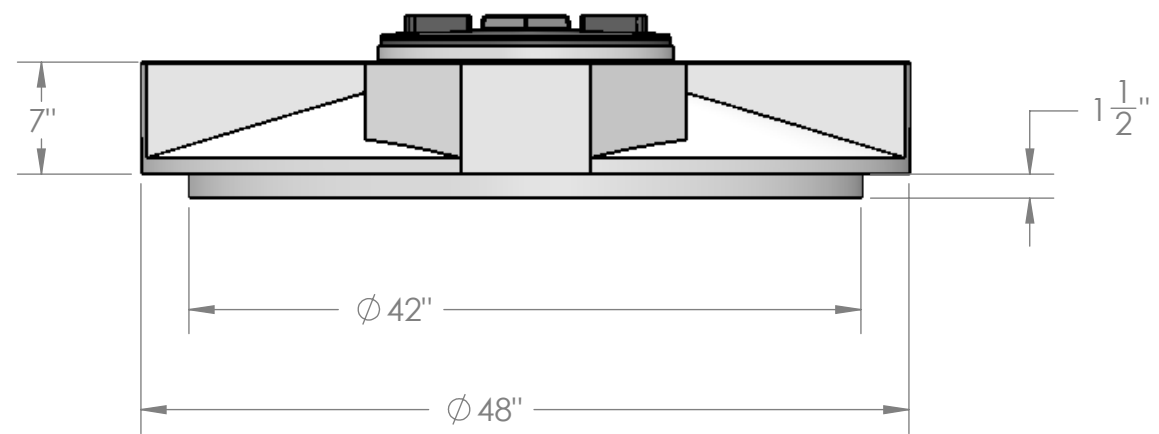

PROPRIETARY AND CONFIDENTIAL
 THE INFORMATION CONTAINED IN THIS DRAWING IS THE SOLE PROPERTY OF <INSERT COMPANY NAME HERE>. ANY REPRODUCTION IN PART OR AS A WHOLE WITHOUT THE WRITTEN PERMISSION OF <INSERT COMPANY NAME HERE> IS PROHIBITED.

		UNLESS OTHERWISE SPECIFIED:		NAME	DATE	CUSTOM ROTO-MOLDING, INC.
		DIMENSIONS ARE IN INCHES TOLERANCES: FRACTIONAL ± ANGULAR: MACH ± BEND ± TWO PLACE DECIMAL ± THREE PLACE DECIMAL ±		DRAWN	10-13-11	
		INTERPRET GEOMETRIC TOLERANCING PER:		CHECKED		TITLE:
		MATERIAL		ENG APPR.		48" DIA. OPEN TOP TANK LID
		FINISH		MFG APPR.		
NEXT ASSY	USED ON	DO NOT SCALE DRAWING		Q.A.		SIZE
APPLICATION				COMMENTS:		DWG. NO.
						48 OTTL
						REV
						SCALE: 1:12 WEIGHT:
						SHEET 1 OF 1

8 7 6 5 4 3 2 1