

8 7 6 5 4 3 2 1

D
C
B
A

D
C
B
A

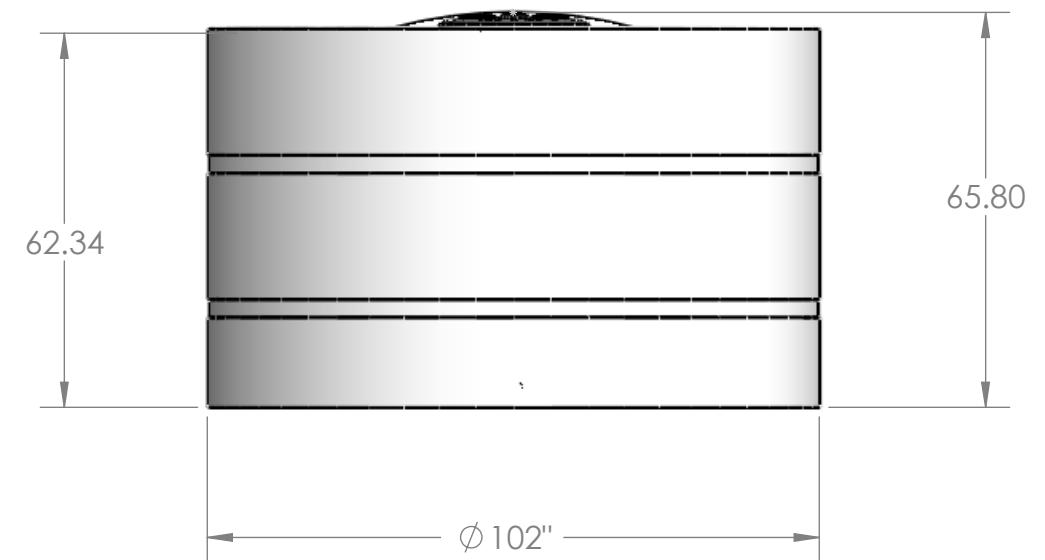
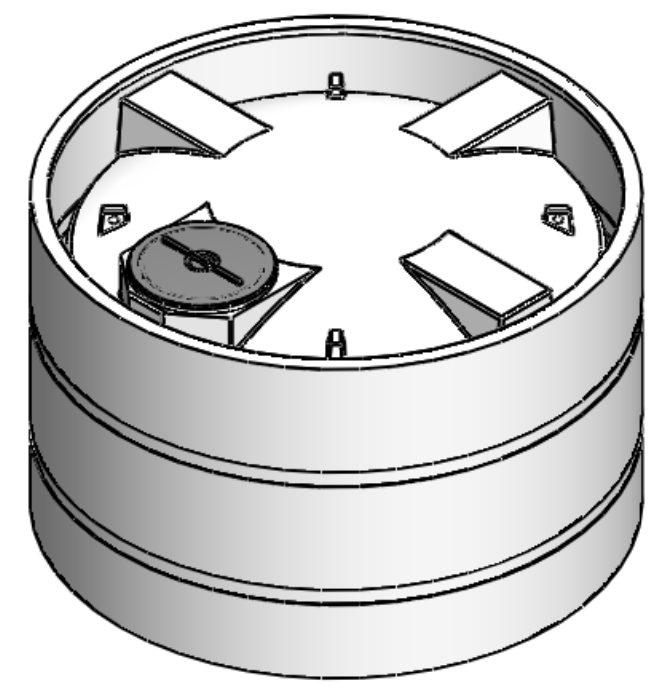
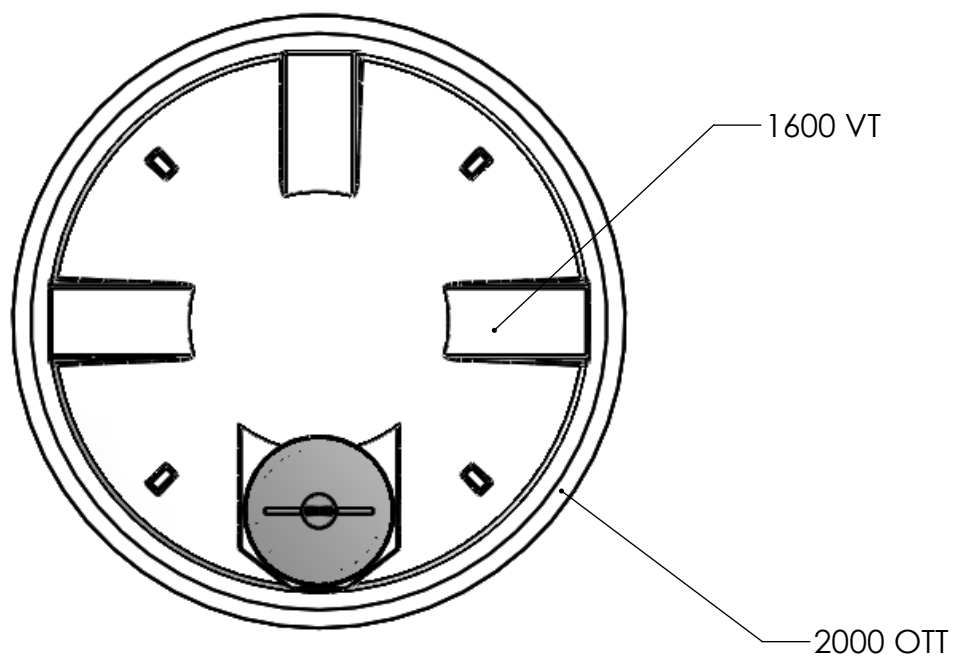

NOTES:

1. MATERIAL: HDPE
2. PRIMARY TANK: STD = 1.5 S.G. 240 LBS
3. CONTAINMENT: STD = 1.5 S.G. 400 LBS
4. SHIPPING WT. 640 LBS.

PROPRIETARY AND CONFIDENTIAL
 THE INFORMATION CONTAINED IN THIS DRAWING IS THE SOLE PROPERTY OF <INSERT COMPANY NAME HERE>. ANY REPRODUCTION IN PART OR AS A WHOLE WITHOUT THE WRITTEN PERMISSION OF <INSERT COMPANY NAME HERE> IS PROHIBITED.

		UNLESS OTHERWISE SPECIFIED:		NAME	DATE	CUSTOM ROTO-MOLDING, INC.	
		DIMENSIONS ARE IN INCHES		DRAWN	EBW	10-22-10	
		TOLERANCES:		CHECKED			TITLE:
		FRACTIONAL ±		ENG APPR.			1600 VT - 2000 OTT
		ANGULAR: MACH ± BEND ±		MFG APPR.			
		TWO PLACE DECIMAL ±		Q.A.			SIZE
		THREE PLACE DECIMAL ±		COMMENTS:			DWG. NO.
		INTERPRET GEOMETRIC TOLERANCING PER:					REV
		MATERIAL					B 1600 VTWC
NEXT ASSY	USED ON	FINISH					SCALE: 1:32 WEIGHT:
APPLICATION		DO NOT SCALE DRAWING					SHEET 1 OF 1

8 7 6 5 4 3 2 1