

8 7 6 5 4 3 2 1

D  
C  
B  
A

D  
C  
B  
A

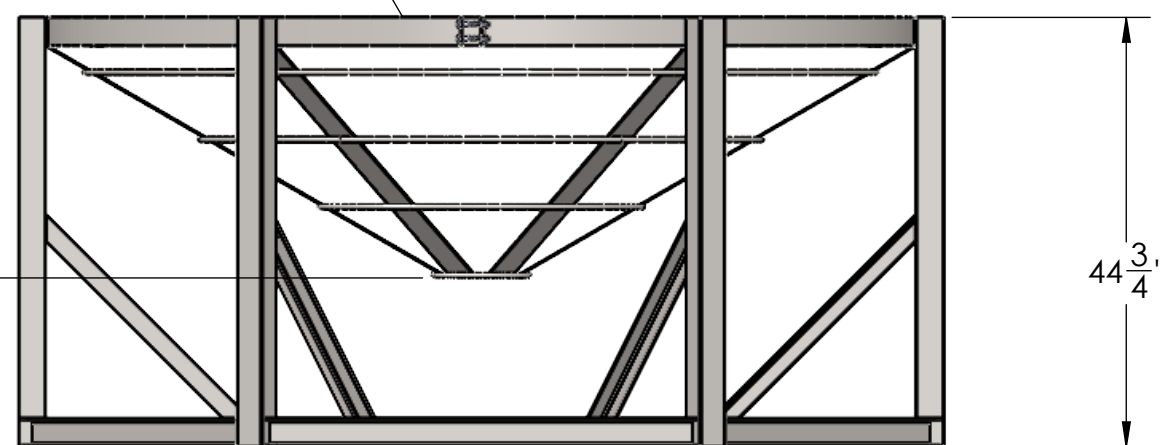
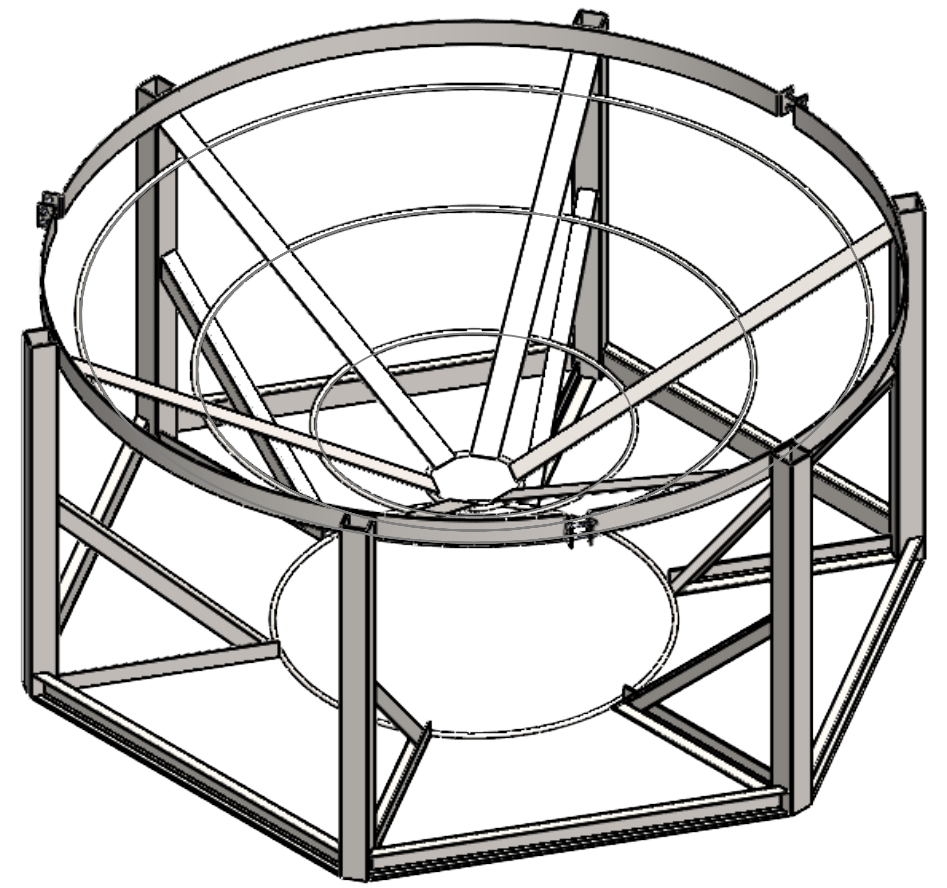
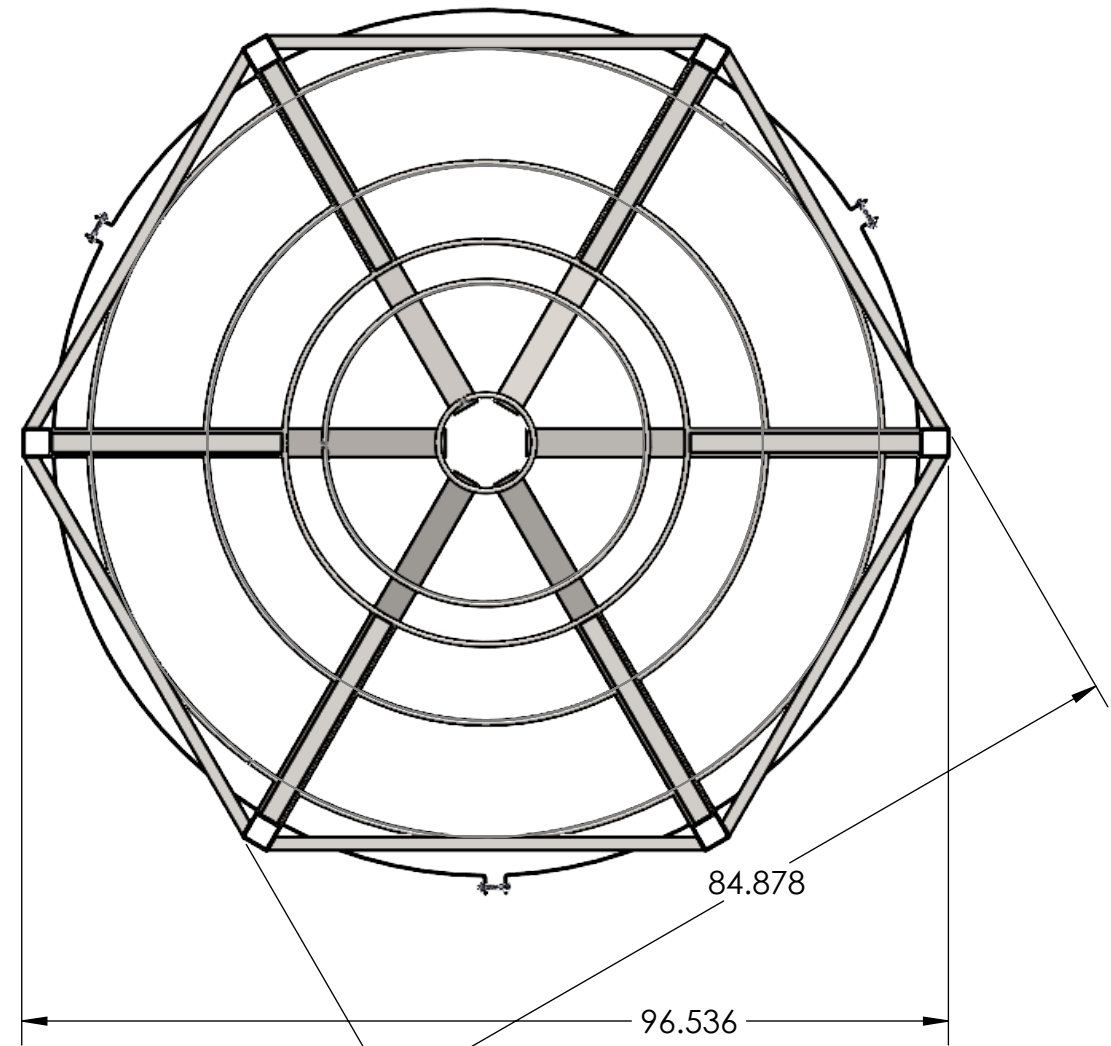

**NOTES:**

- 1. MATERIAL: HRS**
- 2. COLOR: BLACK**
- 3. WEIGHT: 400 LBS.**

**PROPRIETARY AND CONFIDENTIAL**  
 THE INFORMATION CONTAINED IN THIS DRAWING IS THE SOLE PROPERTY OF <INSERT COMPANY NAME HERE>. ANY REPRODUCTION IN PART OR AS A WHOLE WITHOUT THE WRITTEN PERMISSION OF <INSERT COMPANY NAME HERE> IS PROHIBITED.

		UNLESS OTHERWISE SPECIFIED:		NAME	DATE	CUSTOM ROTO-MOLDING, INC.	
		DIMENSIONS ARE IN INCHES		DRAWN	E BW	7-9-12	
		TOLERANCES:		CHECKED			TITLE:
		FRACTIONAL ±		ENG APPR.			<b>90" CONE BOTTOM STAND</b>
		ANGULAR: MACH ± BEND ±		MFG APPR.			SIZE DWG. NO. REV
		TWO PLACE DECIMAL ±		Q.A.			<b>B 90 CBS</b>
		THREE PLACE DECIMAL ±		COMMENTS:			
		INTERPRET GEOMETRIC TOLERANCING PER:					
		MATERIAL					
NEXT ASSY		USED ON					
APPLICATION		DO NOT SCALE DRAWING					
				SCALE: 1:32		WEIGHT: SHEET 1 OF 1	

8 7 6 5 4 3 2 1