

8 7 6 5 4 3 2 1

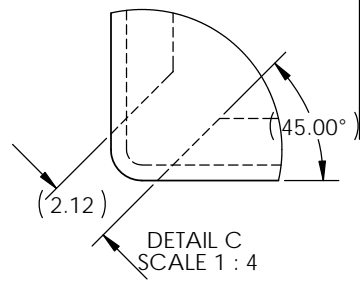

REVISIONS				
ZONE	REV.	DESCRIPTION	DATE	APPROVED

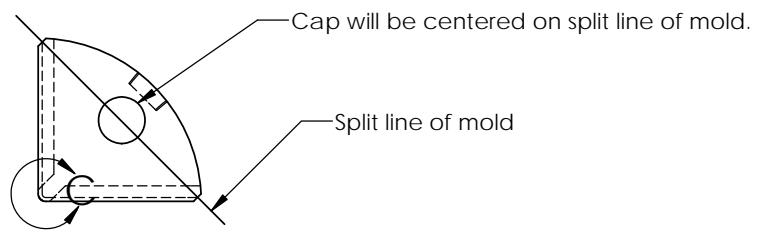
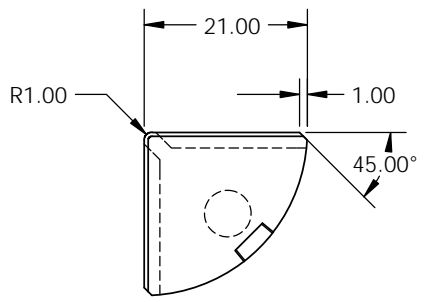
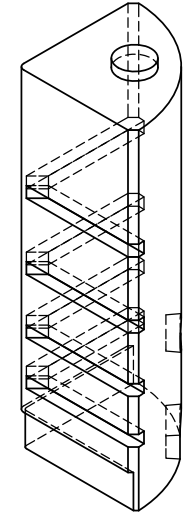
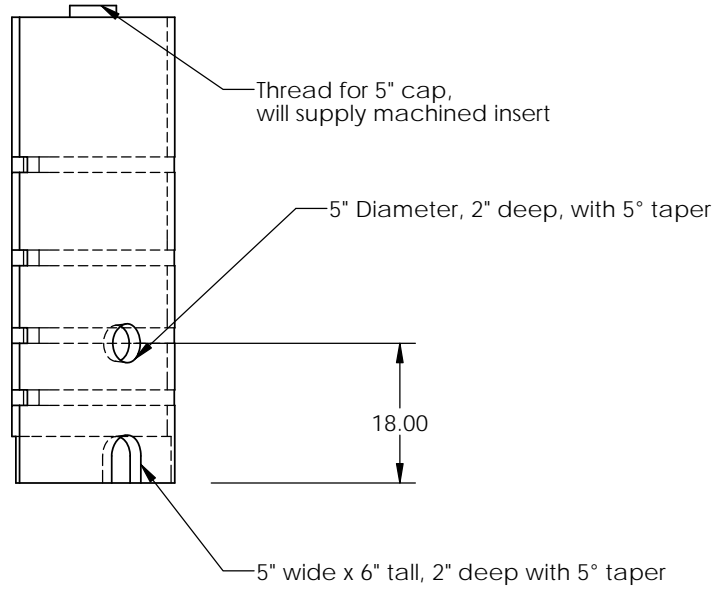
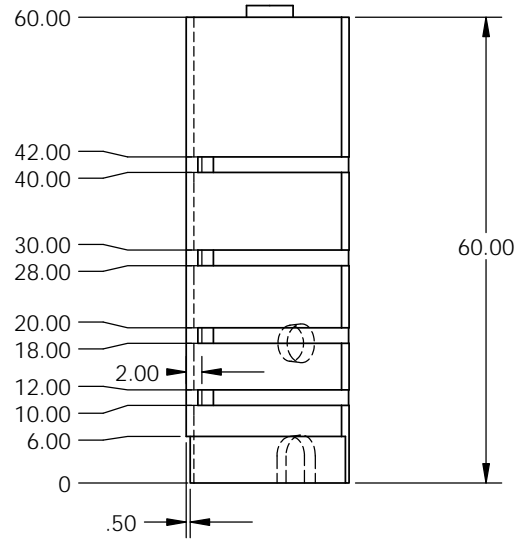

NOTE: All dimensions do not include shrink factor. Add a 2.5% shrink factor to mold unless otherwise specified.

UNLESS OTHERWISE SPECIFIED:
 DIMENSIONS ARE IN INCHES
 TOLERANCES:
 FRACTIONAL ±1/16
 ANGULAR: MACH ±.5° BEND ±
 TWO PLACE DECIMAL ±.03
 THREE PLACE DECIMAL ±.01



PROPRIETARY AND CONFIDENTIAL

TITLE: 80 gallon corner tank		
SIZE B	DWG. NO.	REV B
SCALE: 1:16	WEIGHT:	SHEET 1 OF 1

8 7 6 5 4 3 2 1