

8 7 6 5 4 3 2 1

REVISIONS				
ZONE	REV.	DESCRIPTION	DATE	APPROVED

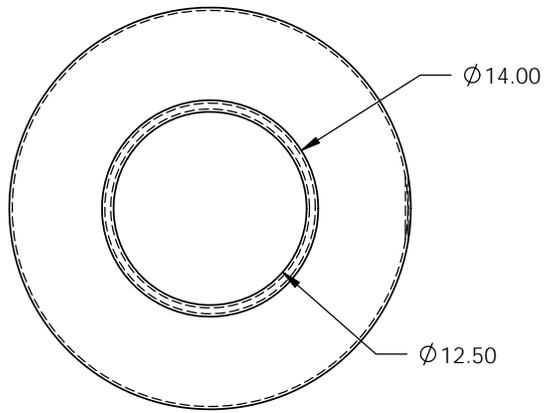

- NOTES:
1. Mold used to make the 100 gallon tank as well.
 2. Gallonage markers to be welded in.
 3. Mold needs to be made from stainless steel.
 4. All dimension include 2.5% shrink factor- DO NOT INCREASE SIZE FOR SHRINK.

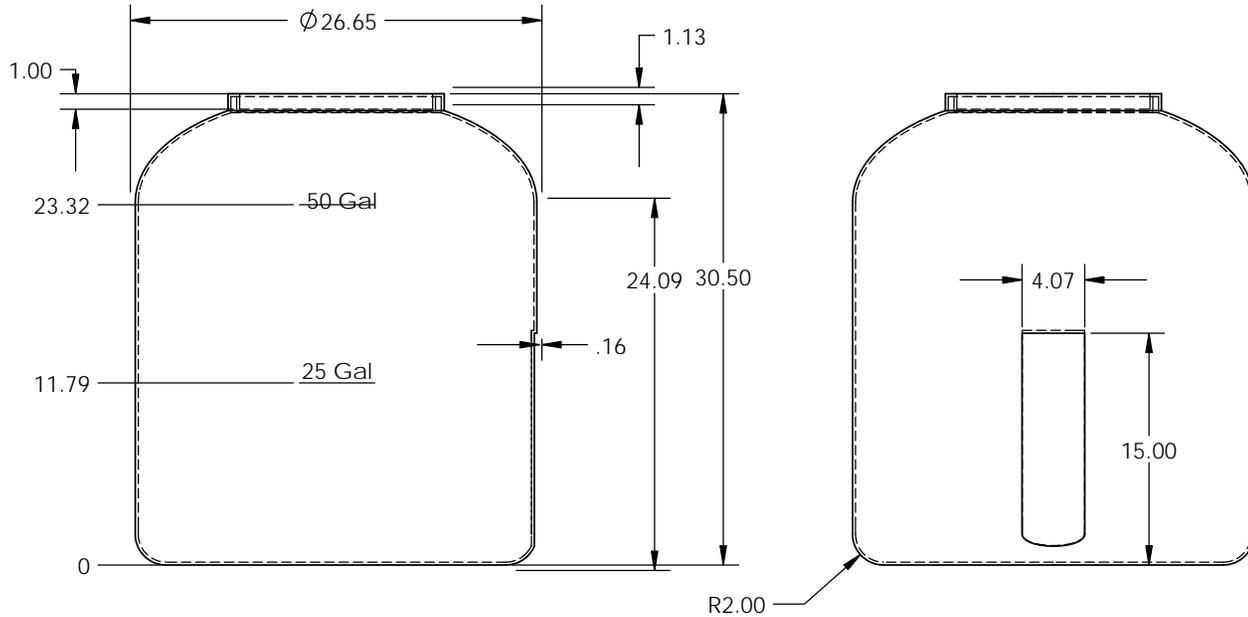
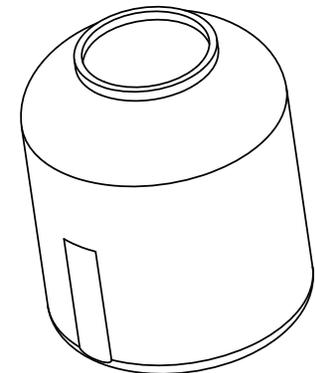

PROPRIETARY AND CONFIDENTIAL

UNLESS OTHERWISE SPECIFIED:			
DIMENSIONS ARE IN INCHES TOLERANCES: FRACTIONAL ±1/16 ANGULAR: MACH ±.5° BEND ± TWO PLACE DECIMAL ±.03 THREE PLACE DECIMAL ±.01			
INTERPRET GEOMETRIC TOLERANCING PER:		TITLE: 65 gallon tank	
MATERIAL:		SIZE B	DWG. NO.
FINISH:		SCALE: 1:12	WEIGHT:
		SHEET 1 OF 1	

8 7 6 5 4 3 2 1

D
C
B
A

D
C
B
A