

REVISIONS				
ZONE	REV.	DESCRIPTION	DATE	APPROVED

- NOTES:
1. Mold used to make the 165 gallon tank as well.
 2. Gallonage markers to be welded in.
 3. Mold needs to be made from stainless steel.
 4. All dimensions include 2.5% shrink factor- DO NOT INCREASE SIZE FOR SHRINK.

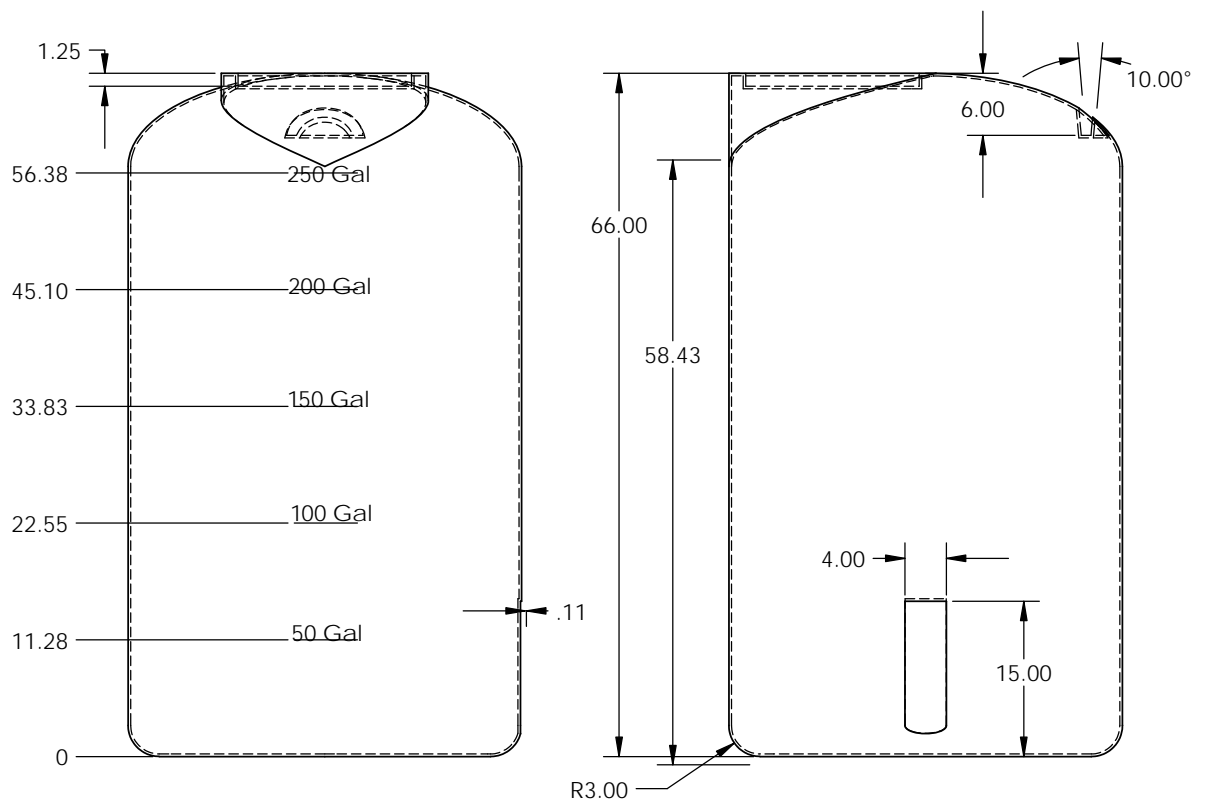
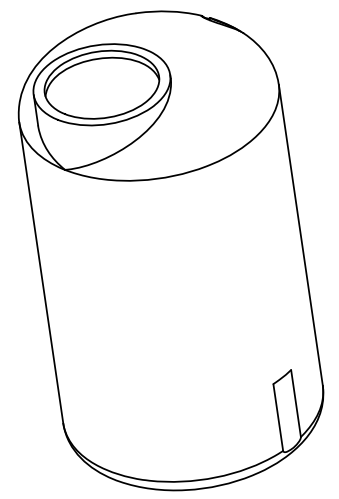

PROPRIETARY AND CONFIDENTIAL

UNLESS OTHERWISE SPECIFIED:
 DIMENSIONS ARE IN INCHES
 TOLERANCES:
 FRACTIONAL $\pm 1/16$
 ANGULAR: MACH $\pm .5^\circ$ BEND \pm
 TWO PLACE DECIMAL: $\pm .03$
 THREE PLACE DECIMAL: $\pm .01$
 INTERPRET GEOMETRIC
 TOLERANCING PER:
 MATERIAL:
 FINISH:



TITLE: 300 gallon tank		
SIZE B	DWG. NO.	REV
SCALE: 1:12	WEIGHT:	SHEET 1 OF 1