

FILL-RITE®

The Most Trusted Name in Pumps and Meters



NX25-120 & NX25-240* FOOT MOUNT SERIES TECHNICAL SPECIFICATIONS

Motor	NX25-120	NX25-240*
Power	120VAC	240VAC (50/60 Hz)
HP (Horsepower) Rating	1/3 HP	
Amps (FLA)	3.5	1.8
RPM	Variable 400 - 3500	
Duty Cycle	Continuous for fuel transfer	
Thermal Protection	Electronically protected	
Certifications	UL/cUL Motor, ATEX, IECEx, CE	

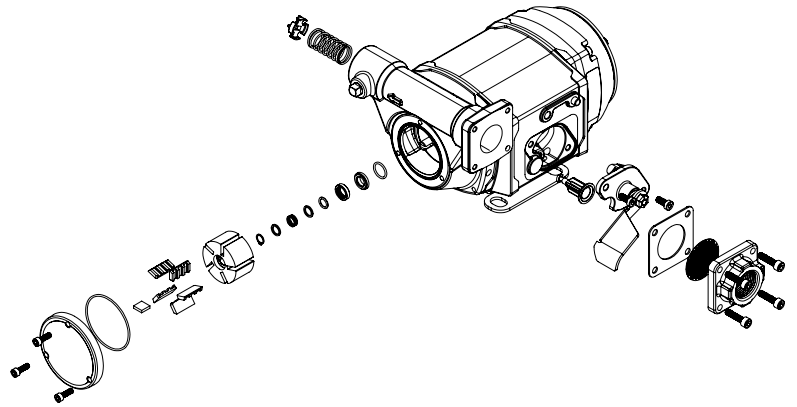

Pump	
Type / Design	Rotary Vane
GPM in Supplied Configuration	25 GPM / 95 LPM**
Bypass Pressure Rating (PSI) - Max	25 PSI
Dry Vac (in Hg)	11
Head - Max	48.5'
Inlet - Size / Thread	1" NPT (BSP available)
Outlet - Size / Thread	1" NPT (BSP available)
Inlet - Material	Cast Iron
Material - Pump Housing	Cast Iron
Material - Wetted Material	Phenolic, Stainless Steel, Steel, Acetal, Thermoset, Buna-N, Fluorocarbon
Rotor Material	Powdered Iron
Rotor Vane Material	Acetal
Compatible Fluids	Diesel, Gasoline, Bio-Diesel up to B20, E15, Kerosene, Mineral Spirits, Methanol (up to 15%)
Strainer Mesh Size	20 x 20
Warranty	2 Years

SERVICE KIT INFORMATION

Kit	Description	Parts
KIT321RK	Overhaul Kit	Rotor, rotor cover, vanes, o-ring seal, shaft seal kit, bypass valve, inlet seal & screen, rotor key, attaching hardware
KIT321RG	Rotary Group	Rotor, vanes, rotor key, gasket, rotor cover, screws
KIT320SL	Shaft Seal	8 piece assembly
KIT321BV	Bypass Kit	Poppet, spring, o-ring, cap
KIT321SK	External Seal Kit	Rotor cover o-ring seal, inlet gasket, screen
KIT321FS	Switch	Switch Assembly
KIT321ASN	Anti-Siphon Kit	Anti-Siphon, Fasteners

*NX25-240 model available in 2020

**Adding accessories will affect flow rate

DIMENSIONAL INFORMATION

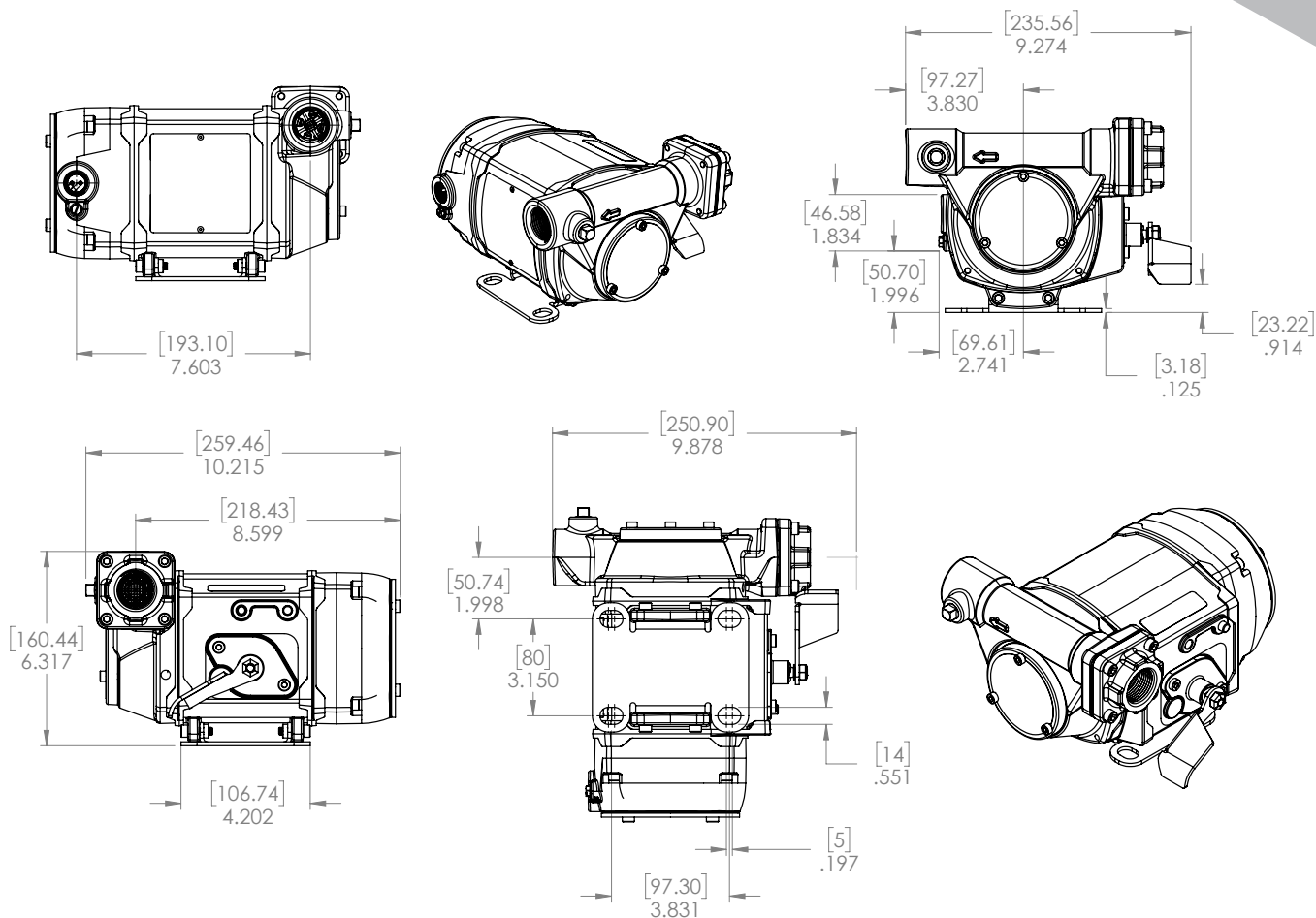

Measurements

Overall Height	6.317"
Overall Width	9.274"
Overall Depth	10.215"
Intake Center Line to Back of Motor Housing	8.599"
Product Weight	21.6 lbs / 9.8 kg
Qty per Pallet	16
Box Dimensions (LxWxH) - Pump Only	18" x 15½" x 10"
Box Dimensions (LxWxH) - Full Kit	21½" x 19½" x 9¾"

Included Accessories

Nozzle - Size	1" NPT-F inlet, 1 1/8" OD spout
Nozzle	Ultra Hi-Flow Automatic
Hose Diameter	1"
Hose Length	18'
Hose Material of Construction	Neoprene exterior
Hose Static Wire (Yes/No)	Yes
Certifications	UL/cUL Listed, ATEX, IECEx, CE

PERFORMANCE CURVE: NX25-120/240* SERIES

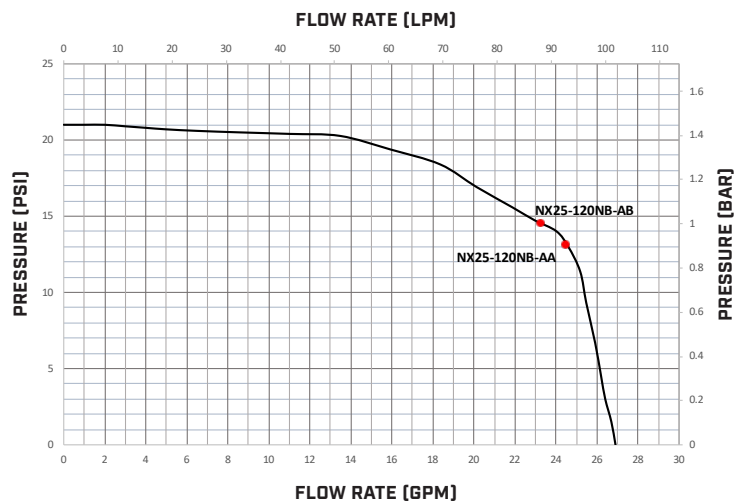

NX25-120 & NX25-240* Pump Models

*NX25-240 model available in 2020