

ST5504

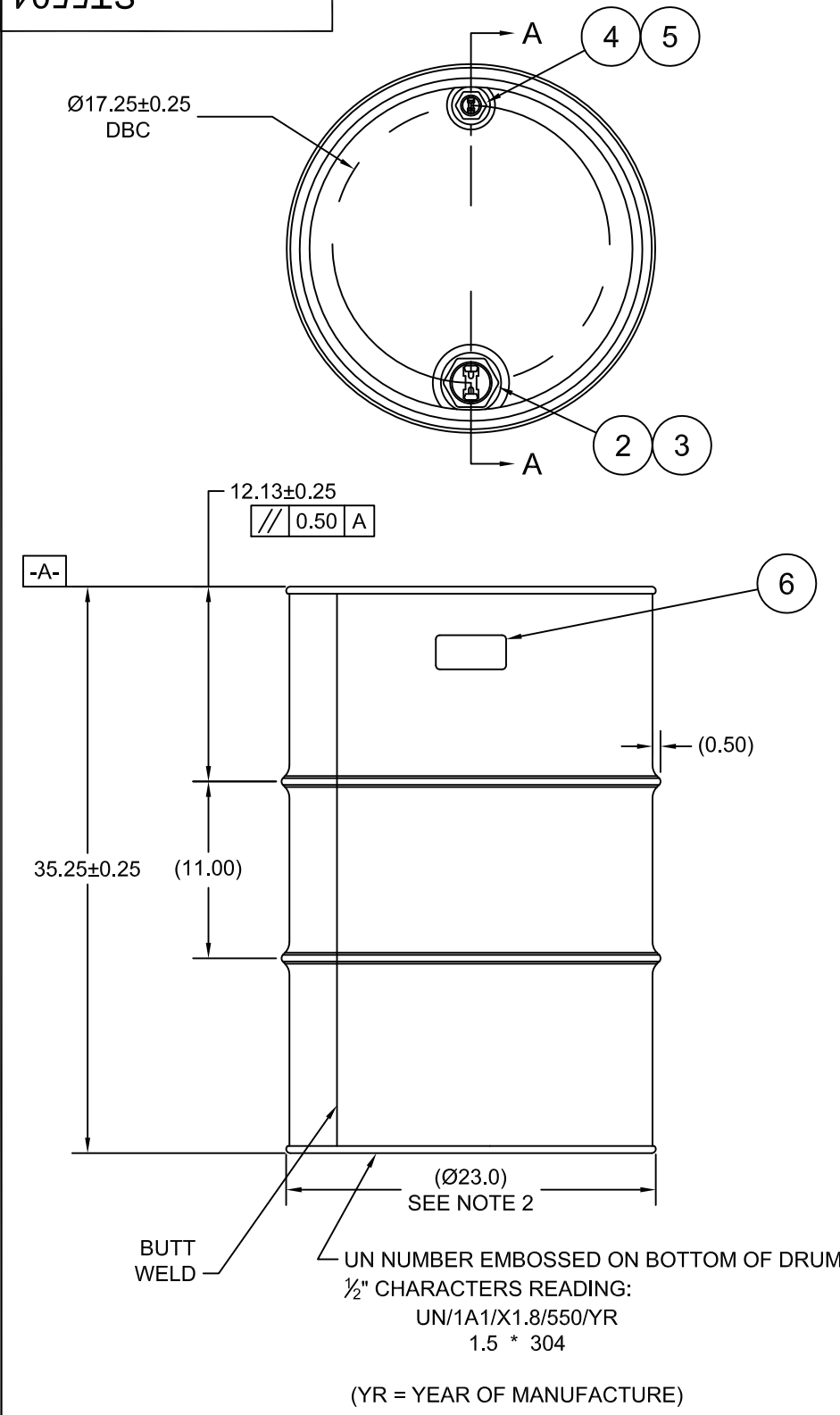

SECTION A-A  
(FITTING SHOWN WITH PLUGS REMOVED)

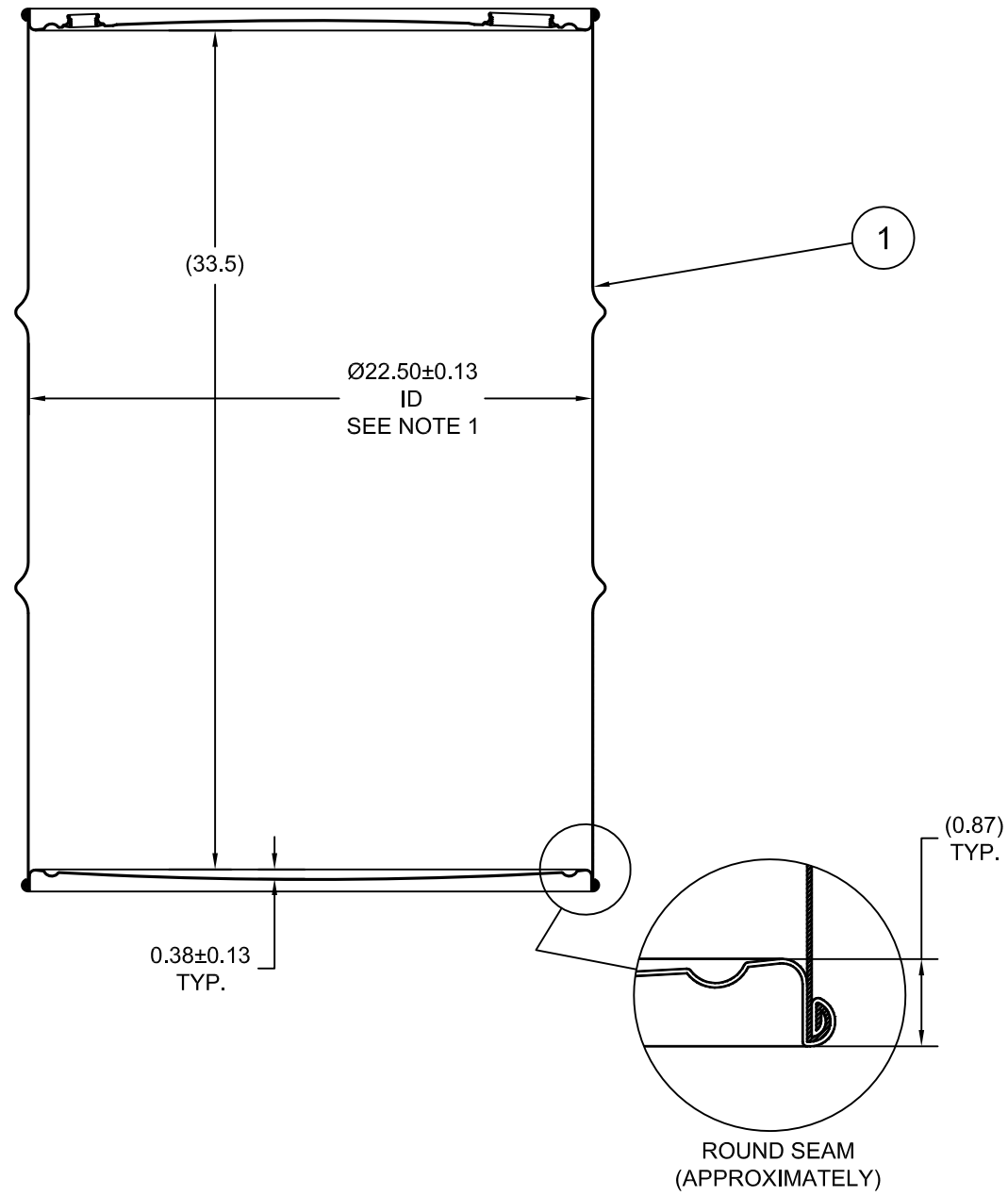

ECN # or INIT	REV	DESCRIPTION	DATE
	A	RELEASED	01-OCT-2007
OE-004		CORRECTED STEEL THICKNESS	
OE-001	A1	CLERICAL ERROR	18-APR-2013

NOTES:

1. TO DETERMINE GREATER ACCURACY OF ANY DIAMETRIC DIMENSION, MEASURING OF CIRCUMFERENCE IS REQUIRED
2. CONSTRUCTION per 49 CFR §178.504 (b)

MATERIAL:

1. 304SS PER ASTM A240 OR EQUIVALENT
2. MATERIAL THICKNESS: 1.5mm (0.0543 - 0.0590; 16 GAUGE)

FINISH:

1. PASSIVATED INNER AND OUTER SURFACE OF BODY WELD SEAM

ITEM	P/N	DESCRIPTION	QTY
6		UN DURABLE LABEL	1
5	PT3050	PLUG 3/4 TS 316SS BUNA GASKET	1
4	FT3050	FLANGE 3/4 TS 316SS BUNA GASKET	1
3	PT2050	PLUG 2 TS 316SS BUNA GASKET	1
2	FT2050	FLANGE 2 TS 316SS BUNA GASKET	1
1		55 GALLON TIGHT HEAD DRUM	1

MFG JR	DRW LJT	CHK LJT	UNLESS STATED OTHERWISE (DIMENSIONS IN PARENTHESIS ARE FOR REFERENCE ONLY!!!) ALL DIMENSIONS ARE IN INCHES DO NOT SCALE DRAWING TOLERANCES: FRACTIONS ±1/4 X° ± 3° X.X ± 0.2 X.XX ± 0.10 X.XXX ± 0.030
SLS DR	QA MD	APR Jesse Sanchez	
FILE CREATED IN AutoCAD 2002		3 <sup>RD</sup>	

<b>SKOLNIK INDUSTRIES, INC.</b> 4900 SOUTH KILBOURN AVENUE, CHICAGO, IL 60632		
DESCRIPTION 55 GALLON TIGHT HEAD DRUM 1.5 - 1.5 - 1.5 304SS STEEL 1A1/X1.8/550		
REL. DATE 01-OCT-2007	PART NUM. / FILENAME ST5504	REV A1

TARE WEIGHT:  
60 lbs

THE USE OF INFORMATION CONTAINED HEREIN IS RESTRICTED FOR THE BENEFIT OF SKOLNIK INDUSTRIES ONLY. UNAUTHORIZED USE OR DISCLOSURE, COPYING OR OTHERWISE REPRODUCING (IN ANY MANNER) ANY PORTION OF THIS DRAWING WITHOUT PRIOR WRITTEN PERMISSION OF AN AUTHORIZED OFFICIAL OF SKOLNIK INDUSTRIES IS STRICTLY PROHIBITED.