

0Z58WH

ECN # or INIT	REV	DESCRIPTION	DATE
	A	RELEASED	30-MAR-2007
OE-001	A1	CLERICAL ERROR	12-APR-2013
OE-001	A2	CLERICAL ERROR	15-APR-2013

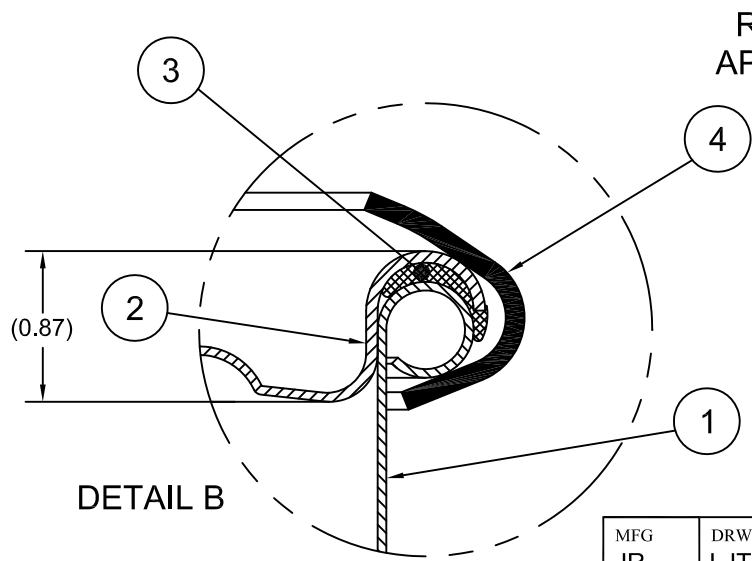
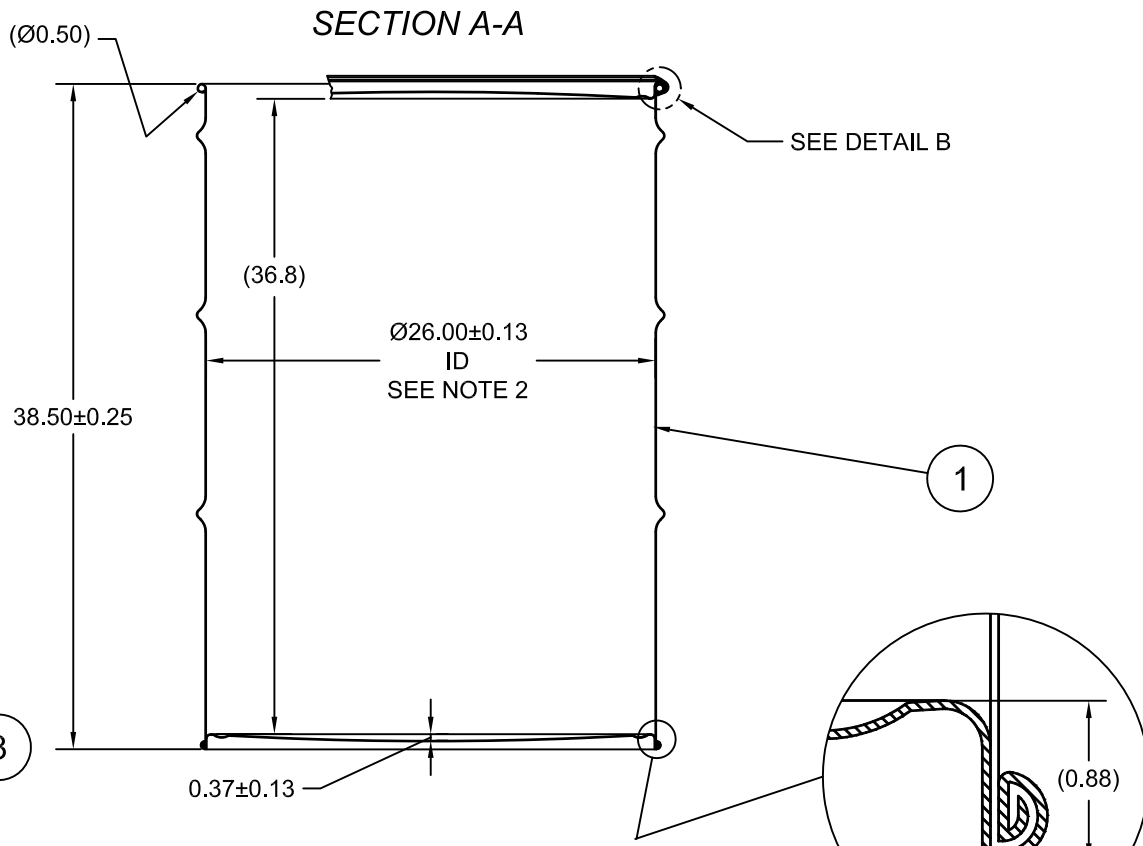
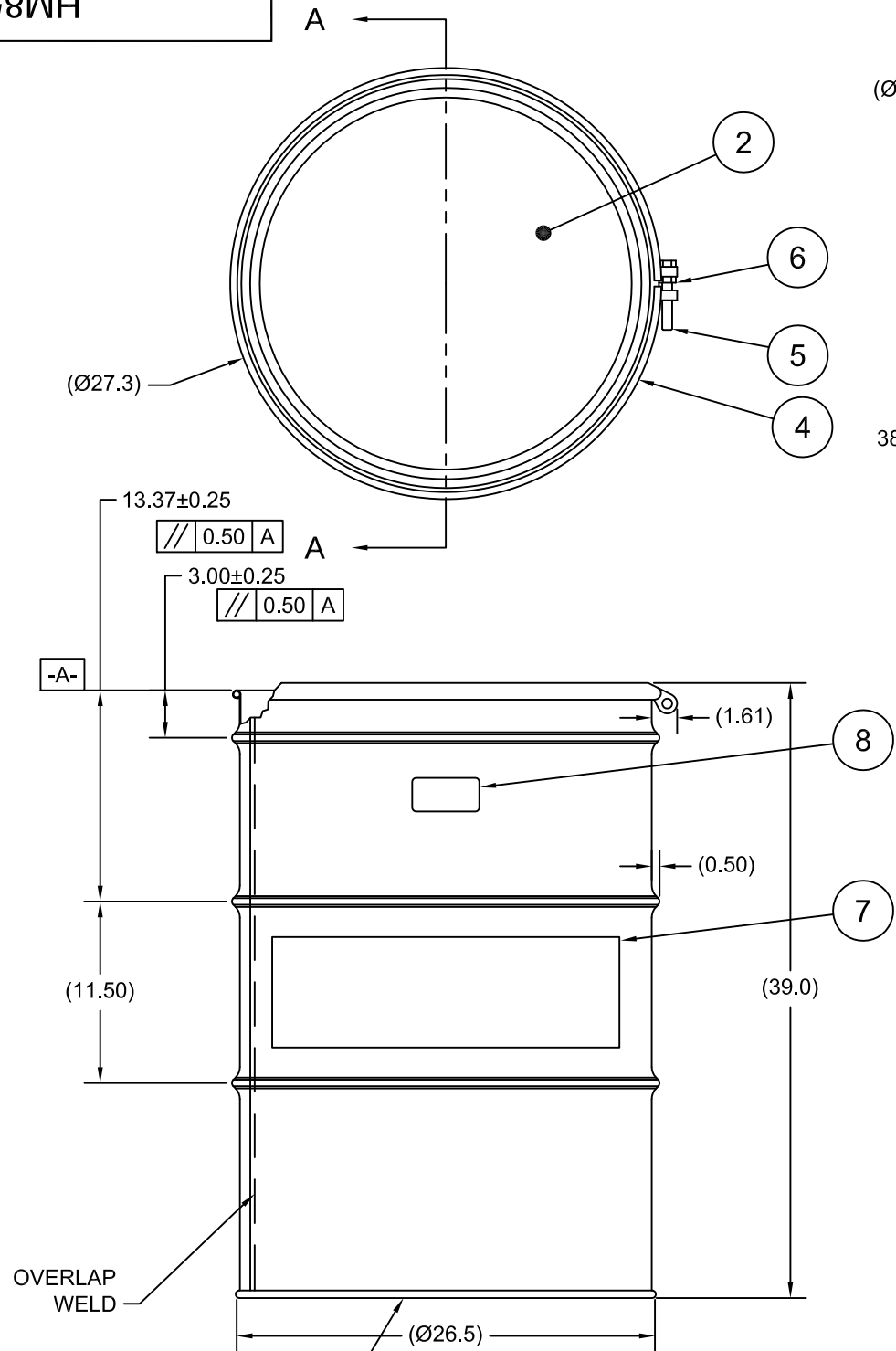

NOTES:

1. THESE DIMENSIONS REPRESENT DRUM AFTER BEING PROPERLY ASSEMBLED AND CLOSED PER SKOLNIK CLOSING INSTRUCTIONS
2. TO DETERMINE GREATER ACCURACY OF ANY DIAMETRIC DIMENSION, MEASURING OF CIRCUMFERENCE IS REQUIRED
3. CONSTRUCTION per 49 CFR §178.504 (b)

MATERIAL:

1. DRUM BODY AND COVER CRCQ CARBON STEEL PER ASTM A1008 AND ASTM A568 OR OR EQUIVALENT
2. MATERIAL THICKNESS COVER 1.2mm (0.0433 - 0.0480; 18 GAUGE), BODY/BOTTOM 0.9mm (0.0319 - 0.0370; 20 GAUGE).
3. GASKET MAT'L PER ASTM D1056

FINISH:

1. BODY/BOTTOM EXTERIOR PAINTED GRAY #716 (LQ10011)
COVER EXTERIOR PAINTED RED (LQ10017)

ITEM	P/N	DESCRIPTION	QTY
8		UN DURABLE LABEL	1
7	LS0500	LOGO MULTI-LINGUAL SALVAGE DRUM	1
6	NT5800	5/8-11UNC HEX JAM NUT	1
5	BT5840	5/8-11UNC X 4in LONG HEX HEAD BOLT	1
4	RBH2612	BOLT RING (HP) 79-96G 12 GA 5/8 LUG	1
3	GE8500	GASKET EPDM IN-COVER D	1
2	P2612	COVER Ø26 ID, 18 GA	1
1		BODY/BOTTOM 85 GALLON DRUM Ø26 ID	1

UN NUMBER EMBOSSED ON BOTTOM OF DRUM
1/2" CHARACTERS

UN/1A2/Y440/S/YR

1.2 - 0.9 - 0.9 *

(YR = YEAR OF MANUFACTURE)

TARE WEIGHT:
50 lbs

THE USE OF INFORMATION CONTAINED HEREIN IS RESTRICTED FOR THE BENEFIT OF SKOLNIK INDUSTRIES ONLY. UNAUTHORIZED USE OR DISCLOSURE, COPYING OR OTHERWISE REPRODUCING (IN ANY MANNER) ANY PORTION OF THIS DRAWING WITHOUT PRIOR WRITTEN PERMISSION OF AN AUTHORIZED OFFICIAL OF SKOLNIK INDUSTRIES IS STRICTLY PROHIBITED.

MFG JR	DRW LJT	CHK AG
SLS DR	QA MD	
APR Jesse Sanchez		
FILE CREATED IN AutoCAD 2002		

UNLESS STATED OTHERWISE

(DIMENSIONS IN PARENTHESIS ARE FOR REFERENCE ONLY!!!)

ALL DIMENSIONS ARE IN INCHES
DO NOT SCALE DRAWING

TOLERANCES:
FRACTIONS ±1/4

X° ± 3°
X.X ± 0.2
X.XX ± 0.10
X.XXX ± 0.030

SKOLNIK INDUSTRIES, INC.
4900 SOUTH KILBOURN AVENUE, CHICAGO, IL 60632

DESCRIPTION
85 GALLON OPEN HEAD DRUM
1.2 - 0.9 - 0.9 CRCQ STEEL
1A2/Y440/S SOLIDS ONLY

REL. DATE 30-MAR-2007	PART NUM. / FILENAME HM8520	REV A2
--------------------------	--------------------------------	-----------